

# Setting up Skeleton of Bible

## Preview 1st Lecture

**Pastor John Kim**

**The Bible Institute of Holy Land**

Bible(66 books)							
Old Testament(39 books)			400Years Of Silence Period	New Testament (27 books)			
Historical (17)	Psalms (5)	Prophetical (17)		Historical (5)	Epistles (21)	Prophetical (1)  Revelation	
Laws(5)	Job Psalm Proverbs Ecclesiastes Song of Songs	Major(5)		Gospels(4)	Pauline(13)		Matthew Mark Luke John
Genesis Exodus Levites Numbers Deuteronomy		Isaiah Jeremiah Lamentations Ezekiel Daniel		Historical (1)	Rome 1 Cor 2 Cor Galatians Ephesians Philippians Colossians		
Historical (12)		Minor(12)		Acts	1 Thess 2 Thess 1 Timothy 2 Timothy Titus Philemon		
Josua Judges Ruth 1Sam 2 Sam 1 Kings 2 Kings 1 Chronicles 2 Chronicles Ezra Nehemiah Esther		Hesea Joel Amos Obadiah Jonah Micah Nahum Habakkuk Zephaniah Haggai Zechariah Malachi	General(8)	Hebrews James 1 Peter 2 Peter 1,2,3 John Jude			
Over 40 Writers (1400 BC → AD 90) in about 1500 years							

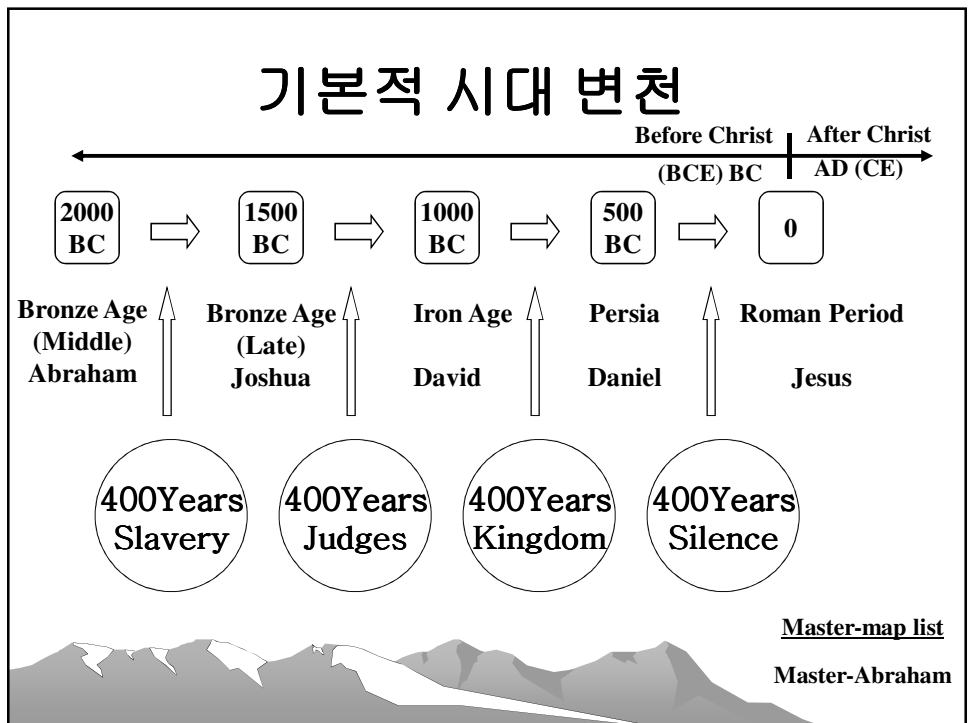
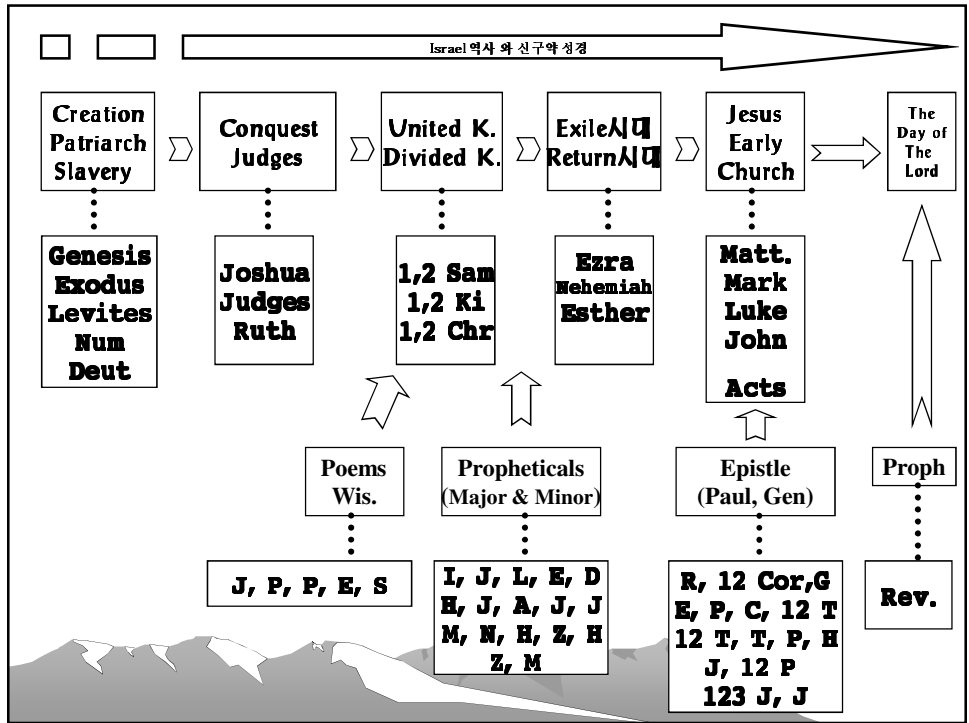

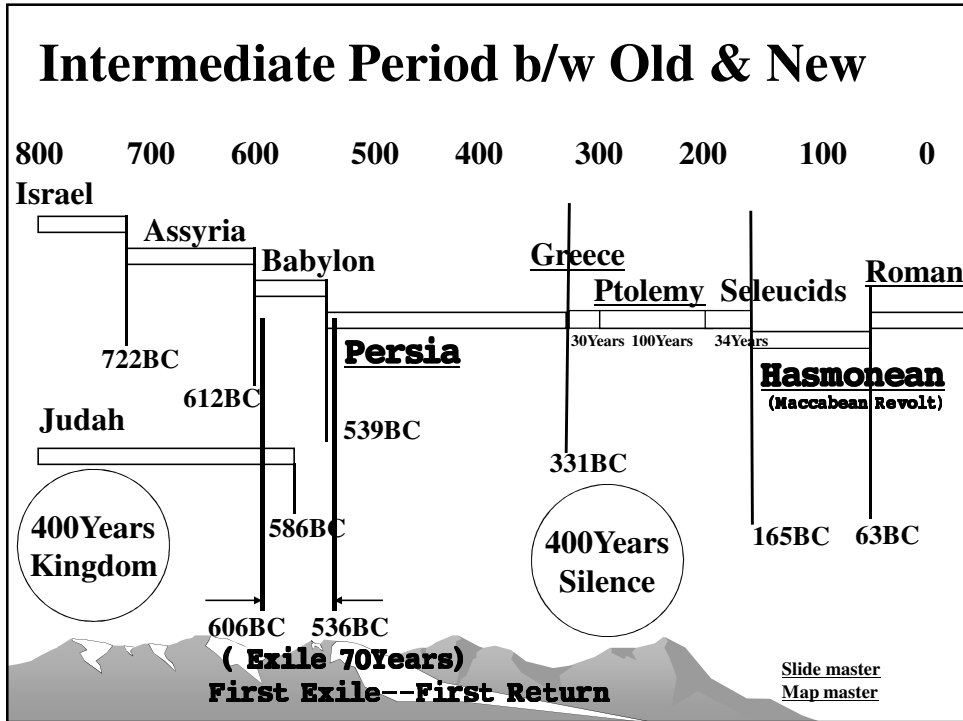
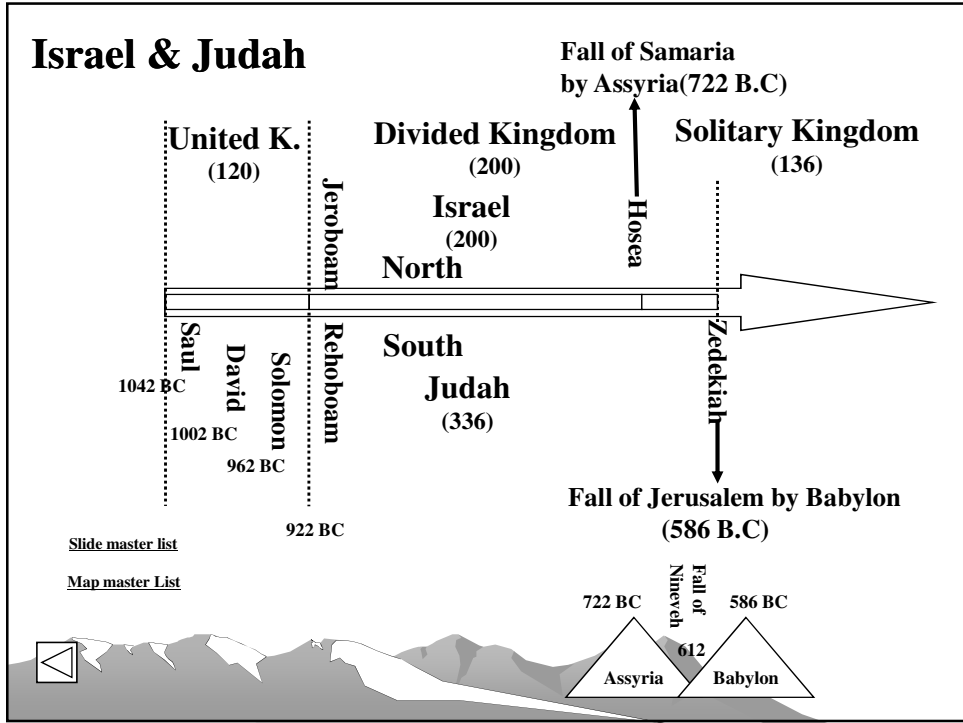

# Political Background

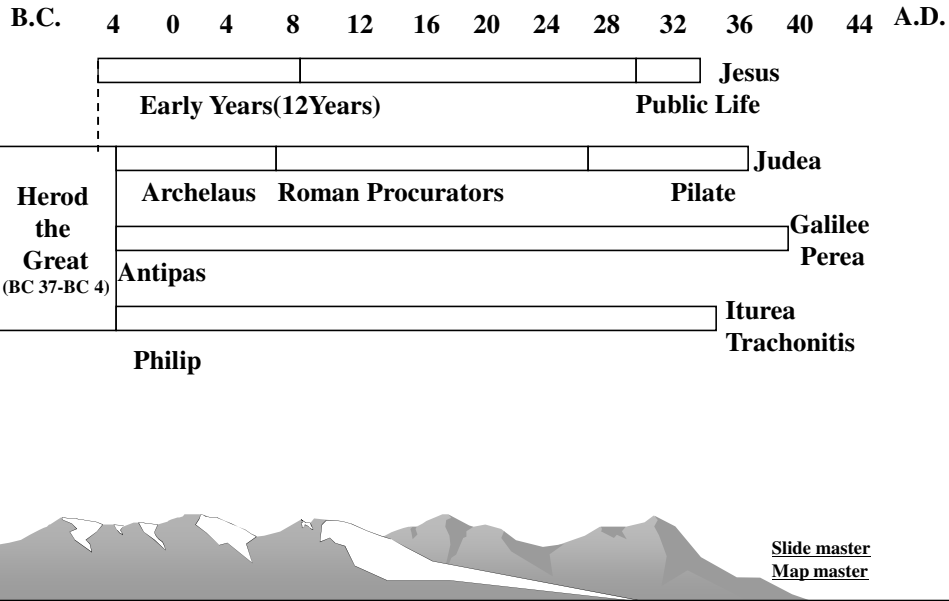

# Political Background

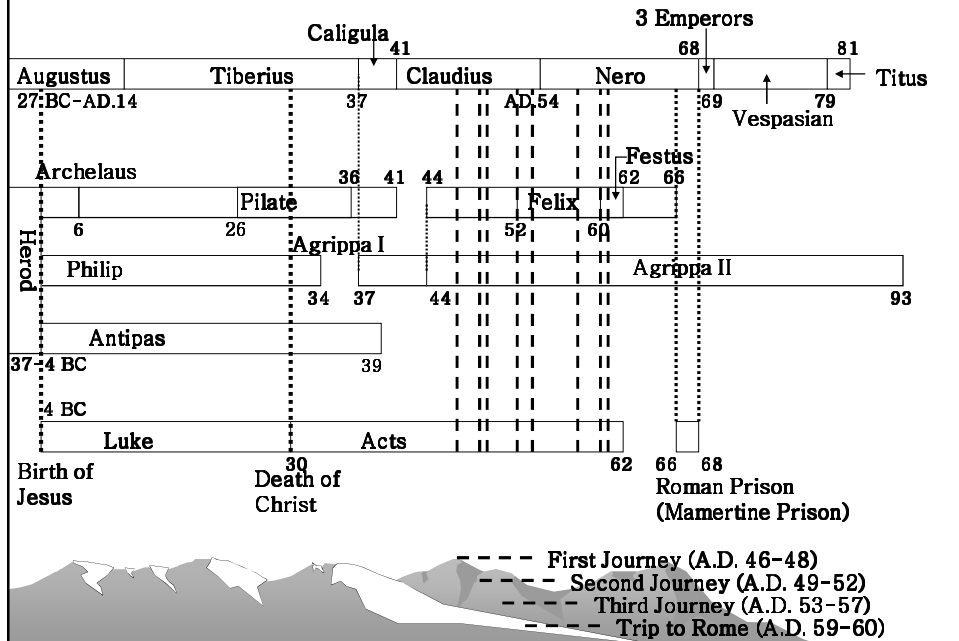

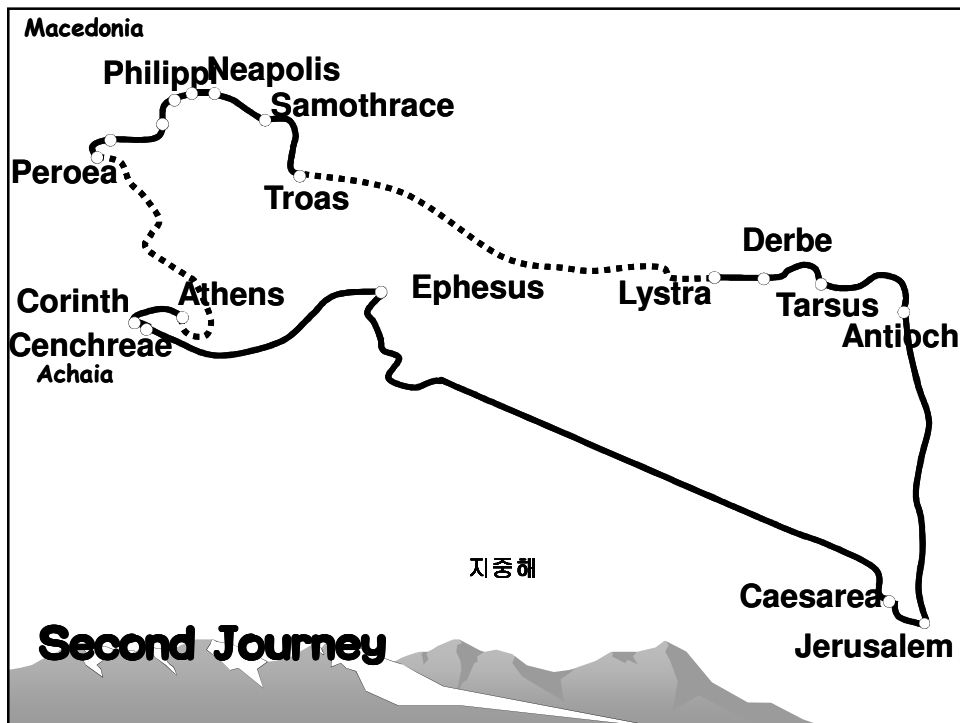
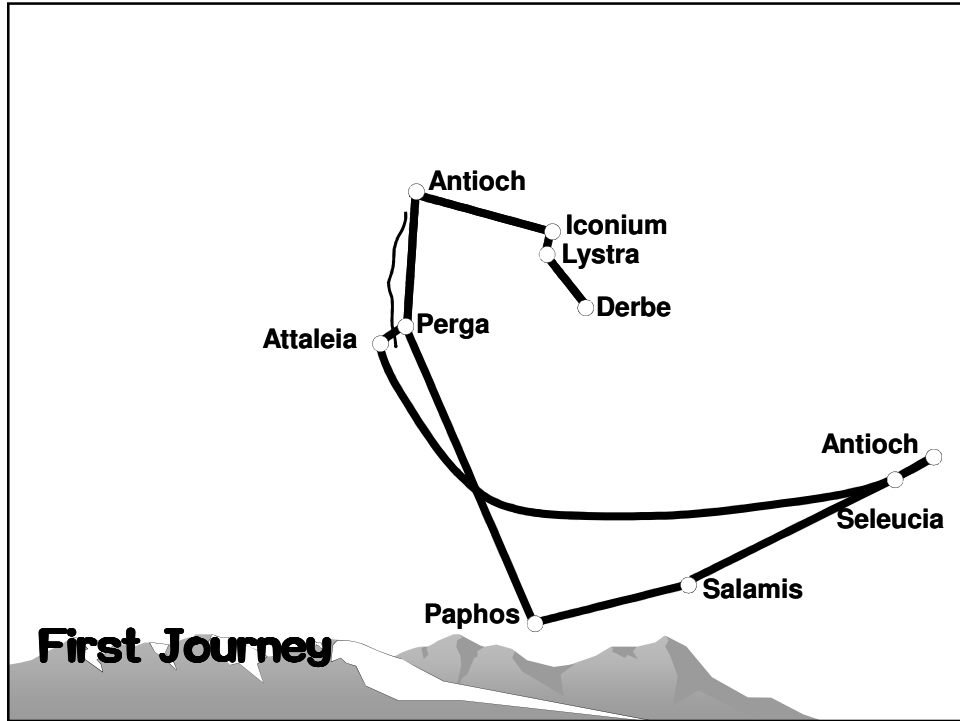

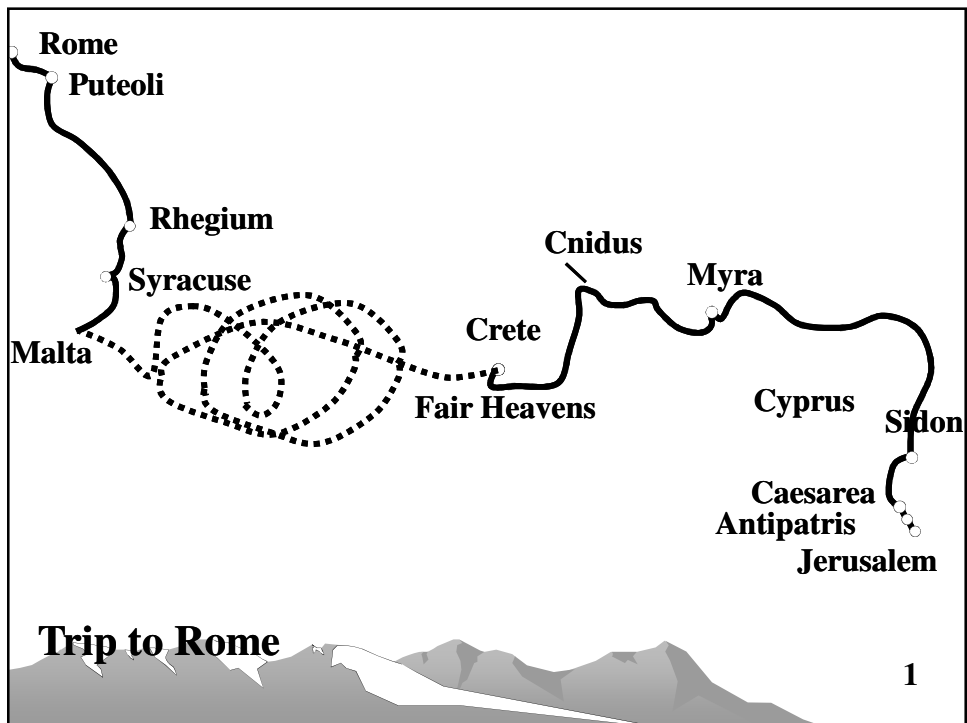
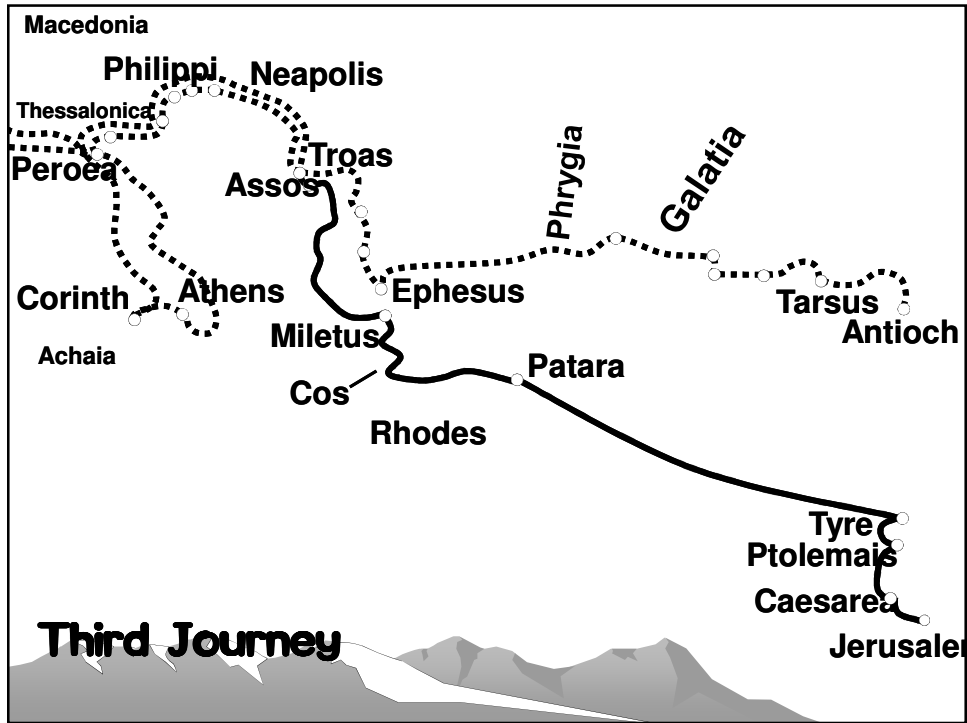

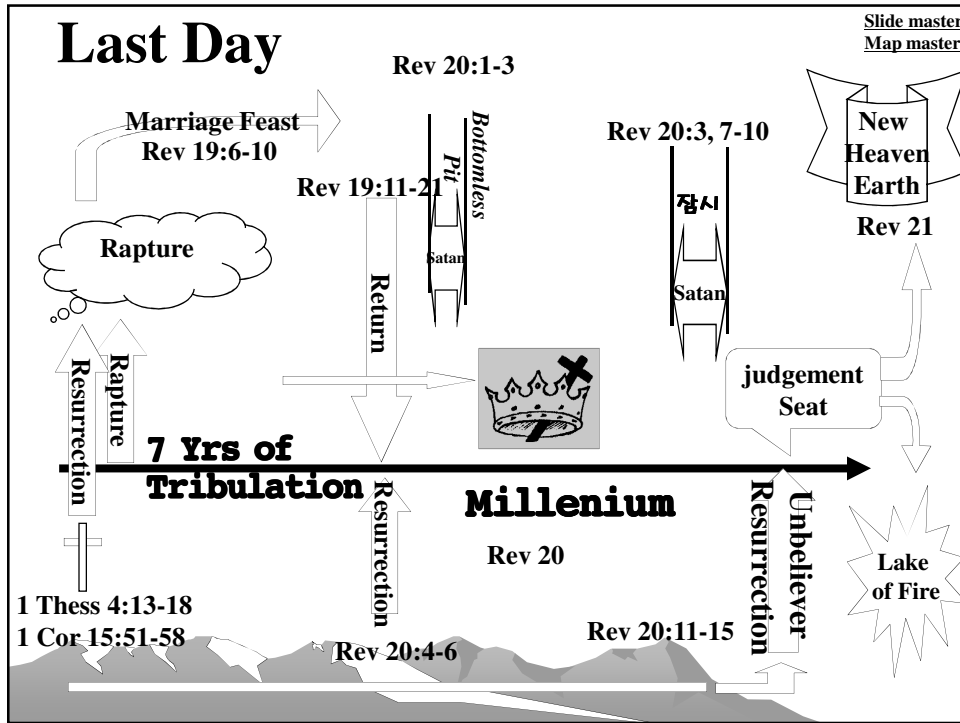

# Promised Land Israel

## Lecture 2

**The Bible Institute of Holy Land**

■ **The Importance of the Study of Geography**

- ✓ Intellectual Understanding of the Bible's narrative...
- ✓ Geography, history, and religion are so intricably bound together in the Bible that the religious message cannot be understood w/o attention to the setting and conditions of the revelation
- ✓ Christianity rests upon the affirmation that a series of events happened, in which God revealed Himself in action, for the salvation of man.

Map-master list

■ **How do we know where to locate a site?**

- ✓ Determine the occurrences of the site name in literary sources.
  - ✓ Distances, proximity to other sites, on/near routes
  - ✓ Other geographical indicators.
- ✓ Toponymy (What does the site name mean)
- ✓ Tradition (Patristic, Talmud, Byzantine, Crusader)

■ **Israel's geopolitical importance**

- ✓ Land b/w 3 continents
  - Africa, Asia & Europe
- ✓ Land b/w the Desert and the Sea
  - ✓ Travel, Trade, Buffer zone (Defensive zone of protection, Launching pad (Extension of supply lines from home))

Map-master list



## How God uses Israel's Geopolitical location?

(Ezk 5:5-8)

- ✓ A small land but coveted by “big power” as an important commercial/military hub.
  - ✓ Ultimately the inhabitants of this land must look to God for security
- ✓ Primary discipline for unfaithfulness
  - ✓ Deut 4:27; 28:63-64  
(The Lord will catter you among people)
  - ✓ 2 Kings 17:5-7
  - ✓ 2 Chr 36:15-20
- ✓ God set his children Israel in a location that could be easily taken

Map-master list

## ✓ Why did God choose THIS as the promised Land?

- ✓ There are better places to live
  - ✓ Mesopotamia
  - ✓ Egypt
- ✓ This Land is His proving ground of faith
  - ✓ Trust God to protect them
    - ✓ In worship (Exod 34:21-24; 1 Ki 8:44, 45)
    - ✓ In war (Deut 17:16; 20:1; Jer 26:16-19; Micah 3:12)
  - ✓ Trust God to provide their daily needs (Matt 6:11)
  - ✓ To display the power of God (Deut 4:38)
  - ✓ To fulfill His own purpose and bring glory to Himself
  - ✓ To teach His people the transitory nature of this life (Heb 11:9-10; 13:14)
  - ✓ To facilitate the propagation of the Gospel (Gal 4:4)  
(Landbridge of three continents)

Map-master list

- ✓ Name for the “Land Between”
  - ✓ Levant (Region on the eastern shore of the Mediterranean Sea from Turkey to Egypt)
  - ✓ Canaan (From “purple”: Greek Phoenician)
  - ✓ Israel (1 Sam 13:19, Used following the Israelite conquest by Joshua)
  - ✓ Palestine
    - ✓ Philistines (the “Sea People” )
  - ✓ Promised Land
    - ✓ Abrahamic Covenant (Gen 17:7)
  - ✓ Holy Land (Set apart for a sacred purpose)
    - ✓ Psalm 78:54, Zech 2:12
  - ✓ Cisjordan/Transjordan
    - ✓ Cis: “on this side”
    - ✓ Trans: “Across”

Map-master list

- Physical Geography of Israel
  - ✓ Only 140 miles (220 km) from Dan to Beersheba
  - ✓ 45 miles (75 km) from the Jordan River to Mediterranean Sea
  - ✓ Yet it contains 50 distinct geographical regions.

Map-master list

# Major Routes

## • Introduction

- ✓ **Not paved (Improvement: remove protruding rocks; smooth out the road)**
- ✓ **How can you identify the ancient roads**
  - ✓ **Roads generally followed by the path of least resistance**
  - ✓ **Routes were used in later history**
  - ✓ **Descriptions in ancient historical sources**
  - ✓ **Archeological discovery of chain of settlements**

## • International Trunk Routes

- ✓ **International Coastal Highway**
  - ✓ **The way of sea**
- ✓ **Transjordan Highway**
  - ✓ **King's Highway: Num 20:17;21:22**
  - ✓ **King's Highway : Deut 2:8**

Map-master list

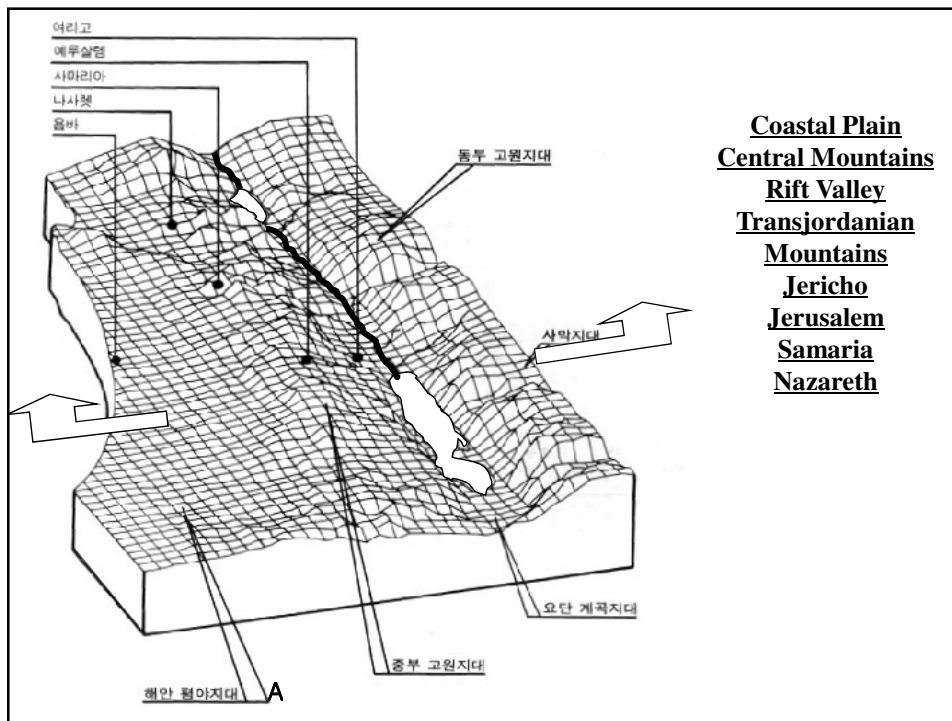

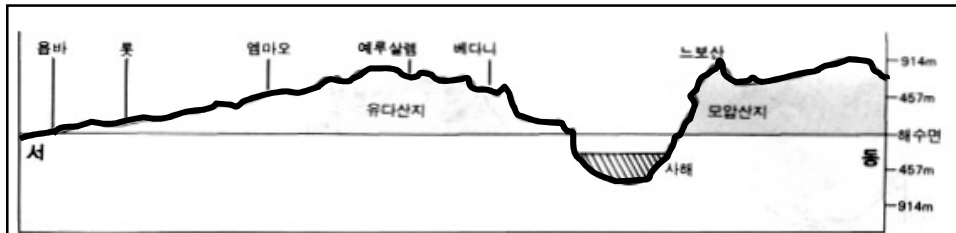

Mt. Nebo  
Moab  
Bethany  
Dead Sea

## Regional Variety

- Coastal Plain
- Jezreel valley
- Western Mountains
- Western foothill, Shephelah
  - 1 Chr 27:28; Obadiah 19
- Negev
- Southern Wilderness
- Jordan Rift Valley
- Eastern Plateau

Map-master list

## Regional Variety

- A land of various segregated tribes and races
  - ✓ At the time of Conquest
    - ✓ Amorite, Perizzites, Hivites, Girgashites, Hittites, Canaanites, Jebusites
  - ✓ Israel maintained its own tribal distinctions for years
  - ✓ The brief period of unification under David and Solomon did not survive
  - ✓ Segmented governmental control at the time of Jesus
    - ✓ Herod Antipas, Herod Philip, Pilate, Decapolis, Samaritans
  - ✓ ToDay' s medley of people
    - ✓ Religious Jews, secular Jews, Arab Muslims, Arab Christians, Other Christians, Bedouin

Map-master list

## Regional Variety

- Problems
  - ✓ Difficult to unify and control various segmented regions within Israel
  - ✓ A strong central government is difficult to establish here
  - ✓ Israel was never unified (Except under David, Solomon & hasmoneans)
  - ✓ Often a “peace” agreement b/w 2 parties will cause concern for a 3<sup>rd</sup> party
    - ✓ Israel + Phoenicia (Ahab+Jezebel) ↔Damascus
    - ✓ Israel + Lebanon ↔Syria (King Assad)
    - ✓ Israel + PLO ↔Jordan (King Hussein)
  - ✓ Future : Under Messiah, local unification will materialize
    - ✓ **isa 2:1-4; 11:12-16; 19:23-24**
    - ✓ **Zech 2:11-12; 9:10, Hag 2:6-9**

Map-master list

■ **Climate**

- ✓ There are no distinct four seasons.
- ✓ Distinct dry and rainy season
  - ✓ Dry Season: 4-9 (7,8:High Temp: Summer)
  - ✓ Wet Season: 10-3 (1-2:Heavy Rain: Winter)

■ **Dry Season**

- ✓ 4-9: (Early April: Late rain, Mid. Sept: Early rain)
- ✓ Almost no humidity except in Plains near Sea

Map-master list

■ **Rainy Season**

- ✓ Oct-March
- ✓ Heavy precipitation (about 600mm/yr)
- ✓ 물보존력이 약하다
- ✓ 가뭄의 기록(Gen 26:1; Jer 14:2-6)
- ✓ Early Rain (Mid Sept-Oct) :Deut 11:14
- ✓ Later Rain(March-April)
- ✓ Most of the Rain (Dec-Feb): Heavy Rain

Map-master list

■ **Agricultural Products**

- ✓ Wheat:
- ✓ Barley:
- ✓ Olives:
- ✓ Grapes:
- ✓ Pomegranates:
- ✓ Figs:
- ✓ Date honey:

■ **Milk & Honey (Exod 3:8, Num 13:27, Deut 11:9)**

- ✓ Milk: livestock
- ✓ Honey: Date honey (Date Palm)

Map-master list

■ **How God works thru the climate and agriculture of the land?**

- ✓ Rain (Jer 3:3)
- ✓ Invasion by a foreign power, exile

■ **Man's response**

- ✓ Success is not assured, you must trust God.
- ✓ Man is not to be complacent or self-confident even with abundance or provision in this world

(Amos 9:13-15)

- ✓ Contentment and rejoicing in the Lord even during material lack (Hab 3:17-18)

Map-master list

● **Tel**

✓ Artificial mound resulting from human occupation(Jos 11:13)

✓ Why did people choose a particular spot?

✓ Strategic, defensible location

✓ Water nearby

✓ Commercial links

✓ Agricultural land

✓ Previous city(building material)

✓ Superstition

✓ Why did people abandon a site?

✓ Famine or plague

✓ Earthquake

✓ War

✓ Migration

Map-master list

✓ Lack of water, Changes in ecological balance

**Creation  
&  
Patriarchs**

**Lecture 3**

**The Bible Institute of Holy Land**





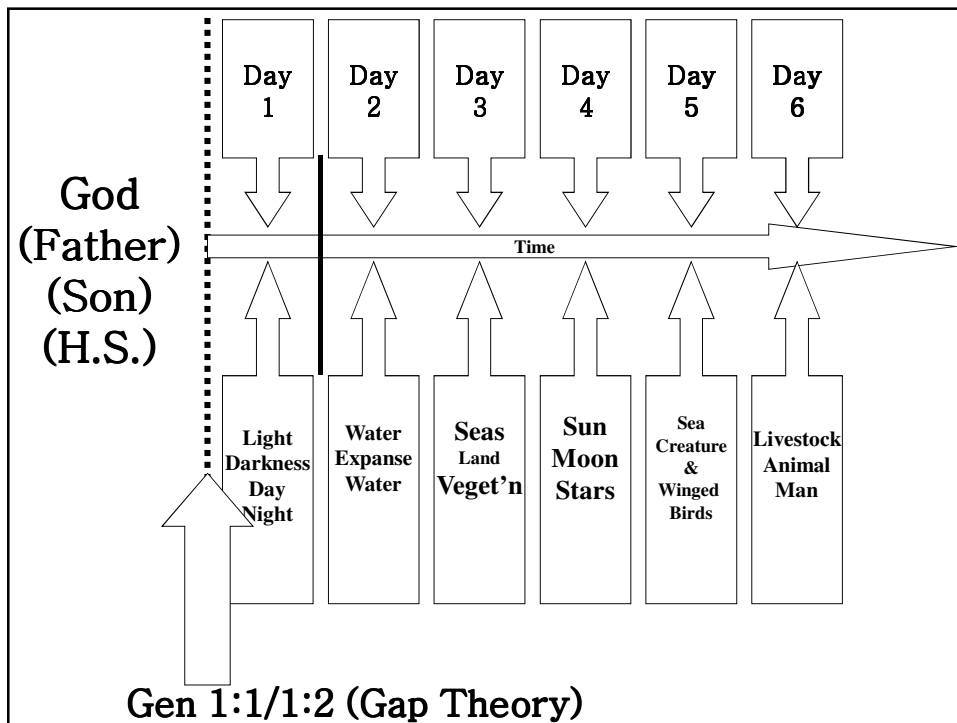
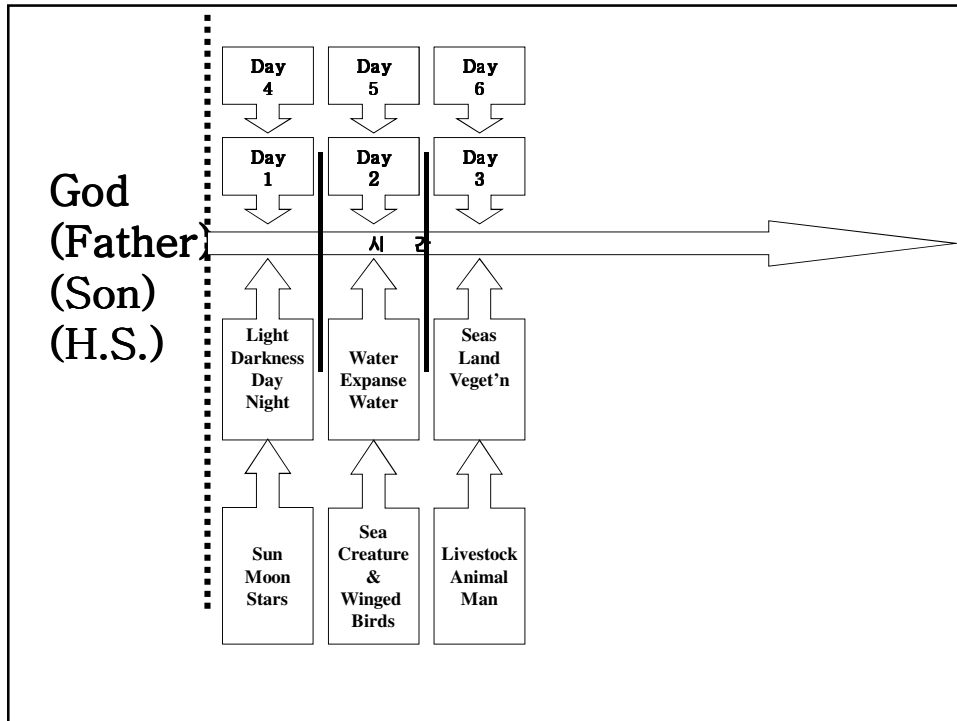

### Geneology Comparison

Chr 3:10-12	Matt 1:8-9
Asa	Asa
Jehozabad	Jehozabad
Joram	Joram
Ahasiah(Uzzia)	Uzzia
Joash	
Amazia	
Azariah	
Jotham	
Ahaz	Ahaz
Hezekiah	Hezekiah
Other Kings	Other Kings

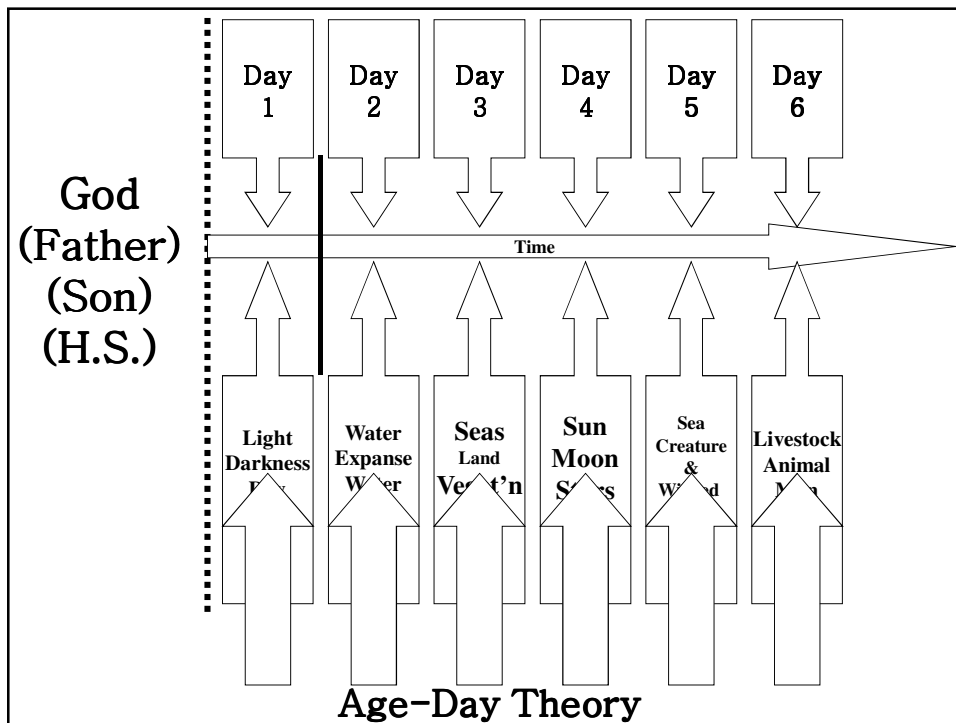

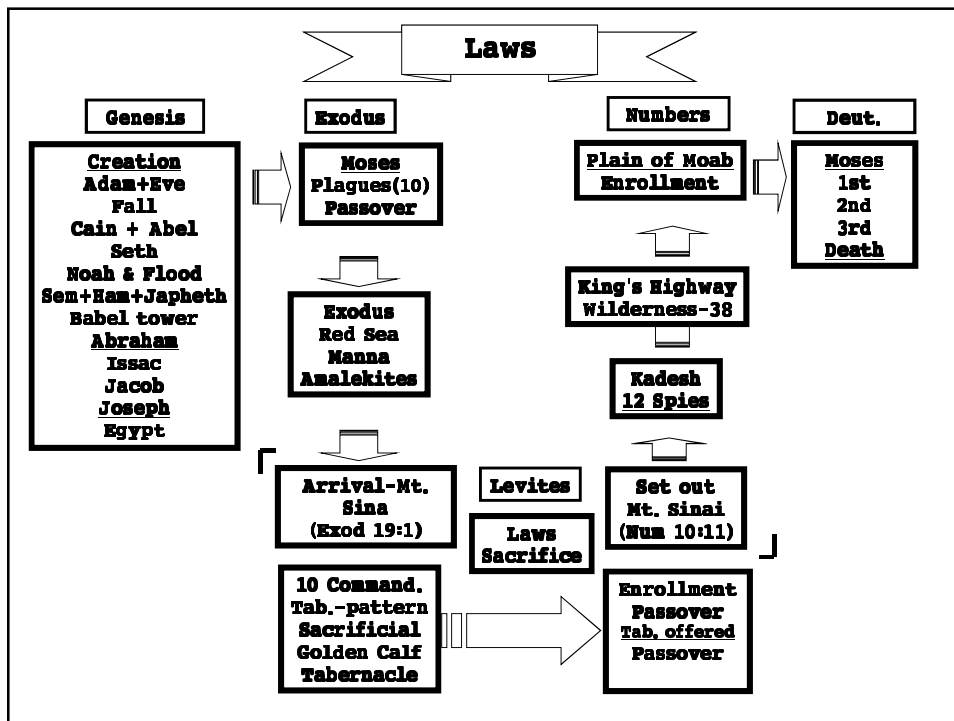
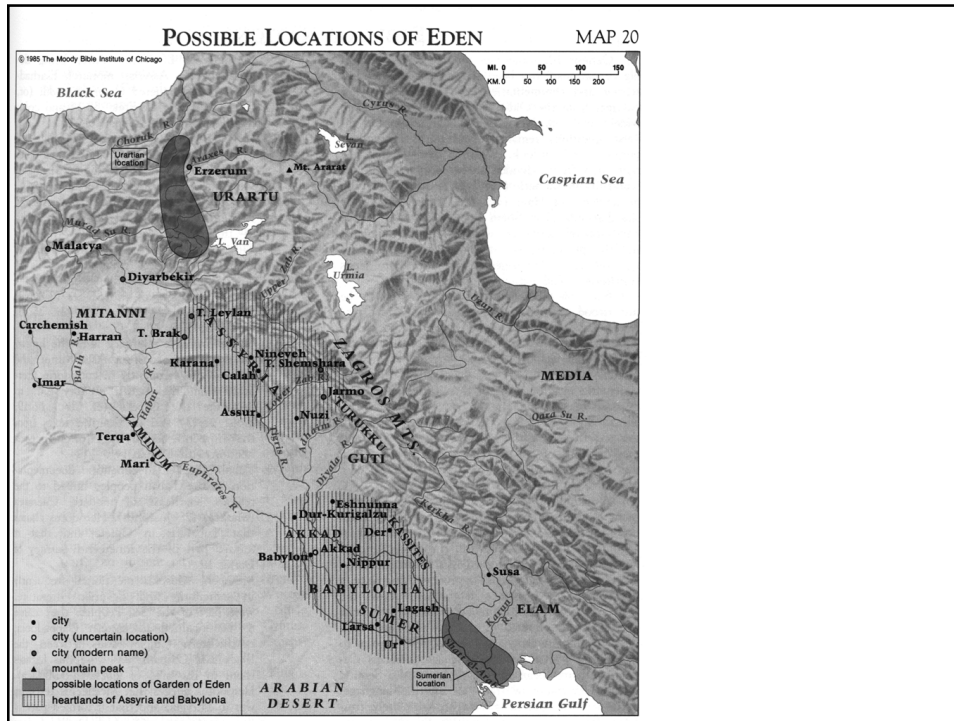

# Abraham

- ✓ Ur and Haran
- ✓ Sechem
- ✓ Bethel and Ai
- ✓ Negev
- ✓ Egypt
- ✓ Negev
- ✓ Bethel and Ai
- ✓ Plain of Jordan
- ✓ Hebron

Master-map list  
Master-Abraham



# Abraham

- ✓ Saving of Lot(Gen 14:1-16)
- ✓ Fall of Sodom and Gomorah
- ✓ Migration to Negev(Gerar)
- ✓ Beersheba(Gen 21:33)
- ✓ Moriah(Gen 22)
- ✓ Death of Sarah(Gen 23):Machpelah
- ✓ Abraham's Old Servant(Gen 24)

Master-map list  
Master-Abraham



## Jacob

(Gen 28-35)

- ✓ Beersheba
- ✓ Bethel (ladder)
- ✓ Haran (20Years):Leah, Rachel, Zilpah, Bilha
- ✓ Jabbok Ford—called Penuel(Israel)
- ✓ Sechem (Dina being sexually abused)
- ✓ Bethel (Built altar and called on the name of the Lord)
  - ✓ God reconfirmed His covenant (Gen 35:11-12)
- ✓ Name-Israel
- ✓ Settle in Hebron : Issac dies [Master-map list](#)

## Joseph

(Gen 37-50)

- ✓ Joseph's Dream
- ✓ Sechem and Dothan
- ✓ Potiphar put him in charge of his household
- ✓ Held in prison and Interpreted dreams
- ✓ Jacob & his families migrated to Egypt
- ✓ Manasseh and Ephraim
- ✓ Death of Jacob and Joseph

[Master-map list](#)  
Master-Abraham  
Master-Joseph

# Moses & Exodus

## Lecture 4

©The Bible Institute of Holy Land

## Moses & Exodus

(Exod 1:1-Deut 34:12)

- ✓ **Moses(40+40+40)**
- ✓ **Exodus**
  - ✓ **Red Sea(Exod 14:13-31)**
  - ✓ **Marah & Elim (Exod 15:23-27)**
  - ✓ **Manna(b/w Elim & Mt. Sinai) (Exod 16:14,15)**
  - ✓ **Water from the Rock:  
Rephidim(Exod 17:1-7)**
  - ✓ **War against Amalekites (Exod 17:8-13)**

Master-map list

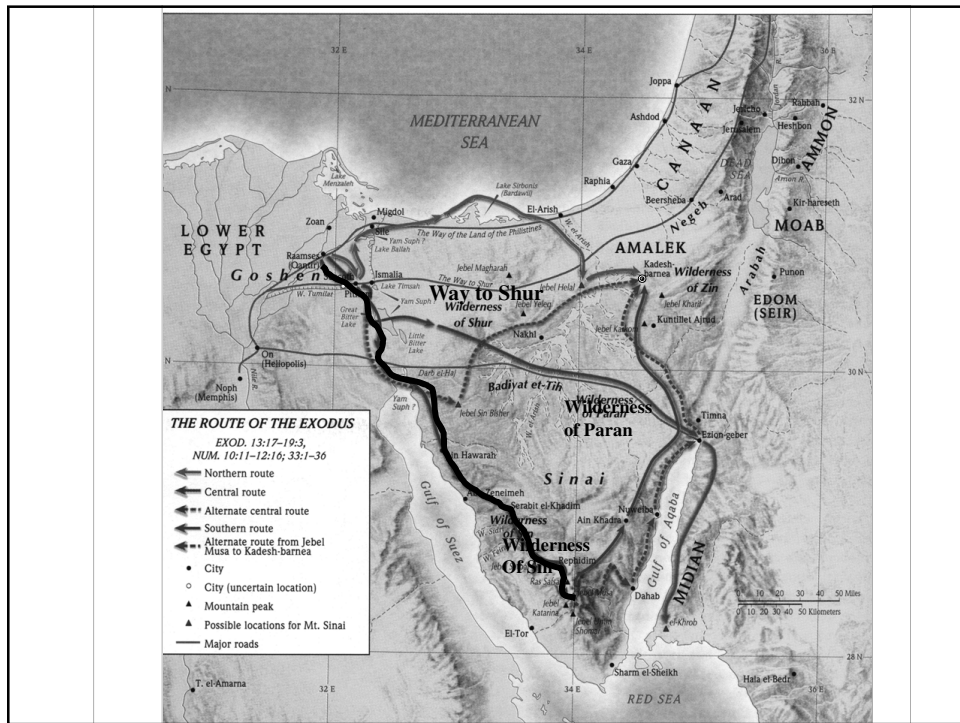
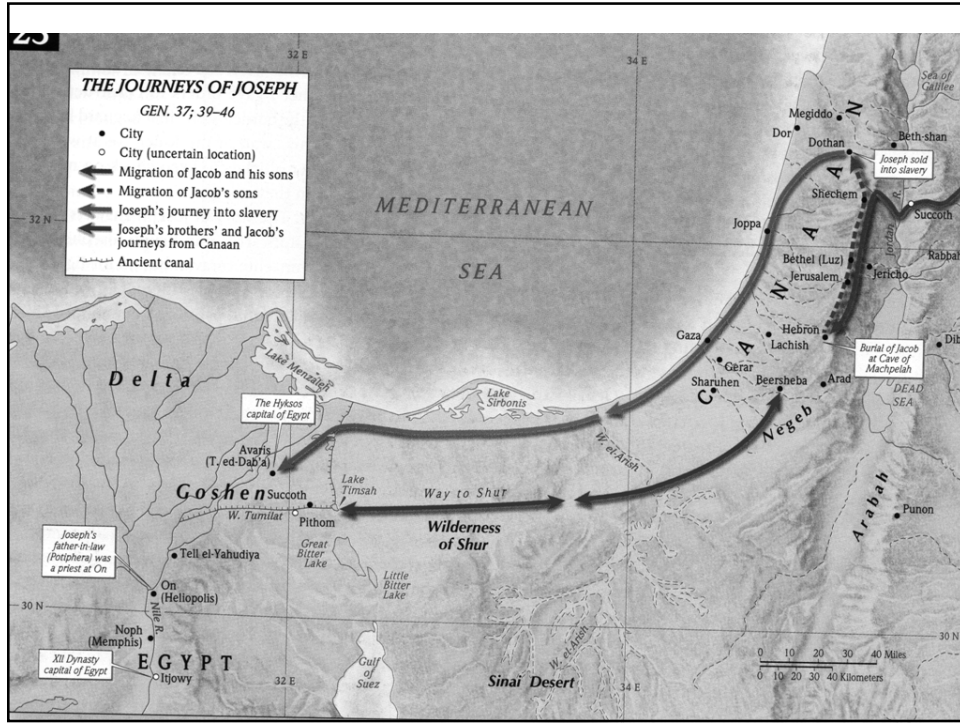

# Moses & Exodus

(Exod 1:1-Deut 34:12)

- ✓ **At Mt. Sinai**
  - ✓ **10 Command.(Exod 20:1-17)**
  - ✓ **Tabernacle (Exod 40:1-38)**
  - ✓ **Laws and Sacrificial law(Levites)**
  - ✓ **First Enrollment (Num 1:1-2:34)**
- ✓ **From Mt. Sinai to Kedesh Barnea**
  - ✓ **Cloud lifted above (Num 10:11-12)**
  - ✓ **Grumbling of Israelites(Num 11:4-6)**
  - ✓ **Quails given(Num 11:31-35)**

Master-map list



<p><b>JOURNEY OF THE SPIES</b> NUM. 13:25-33; NUM. 34:1-12</p> <ul style="list-style-type: none"> <li>• City</li> <li>○ City (uncertain location)</li> <li>◉ Oasis</li> <li>▲ Mountain peak</li> <li>← Journey of the twelve spies</li> <li>■ The promised land</li> </ul>		<p><b>31</b></p> <p>[Num13:17-22 (17)When Moses sent them to explore [Num 13:23-26] (23)When they reached the Valley of Eshcol, they cut off a branch bearing a single cluster of grapes. Two of them carried it on a pole between them, along with some pomegranates and figs. (24)That place was called the Valley of Eshcol because of the cluster of grapes the Israelites cut off there. (25)At the end of forty days they returned from exploring the land. (26)They came back to Moses and Aaron and the whole Israelite community at Kadesh in the Desert of Paran. There they reported to them and to the whole assembly and showed them the fruit of the land of Anak, lived. (Hebron had been built seven years before Zoan in Egypt.)</p>
--	--	---



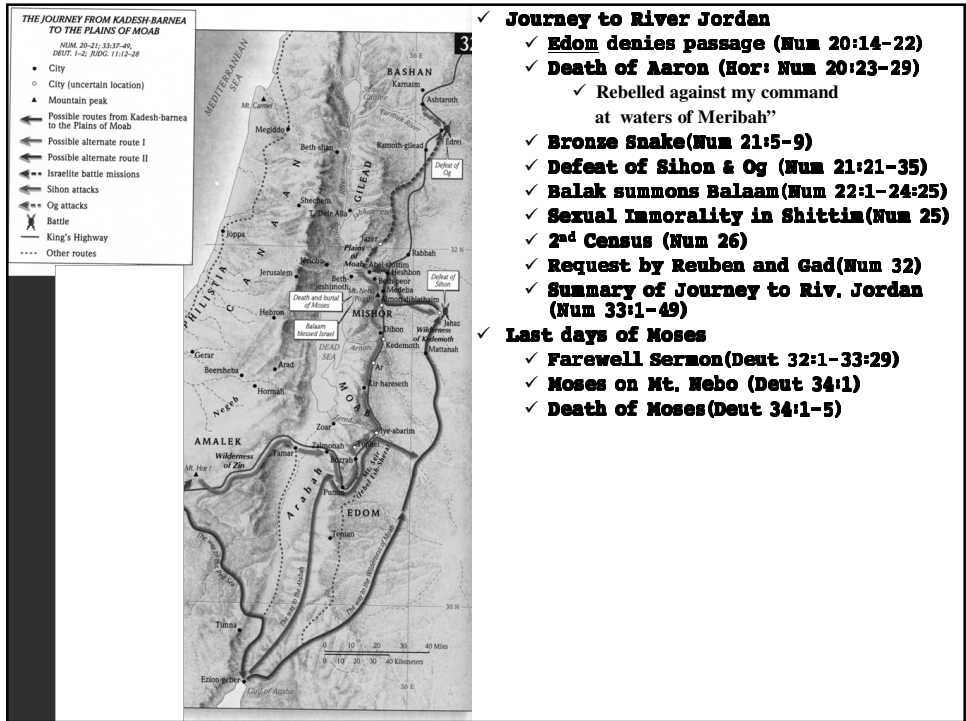
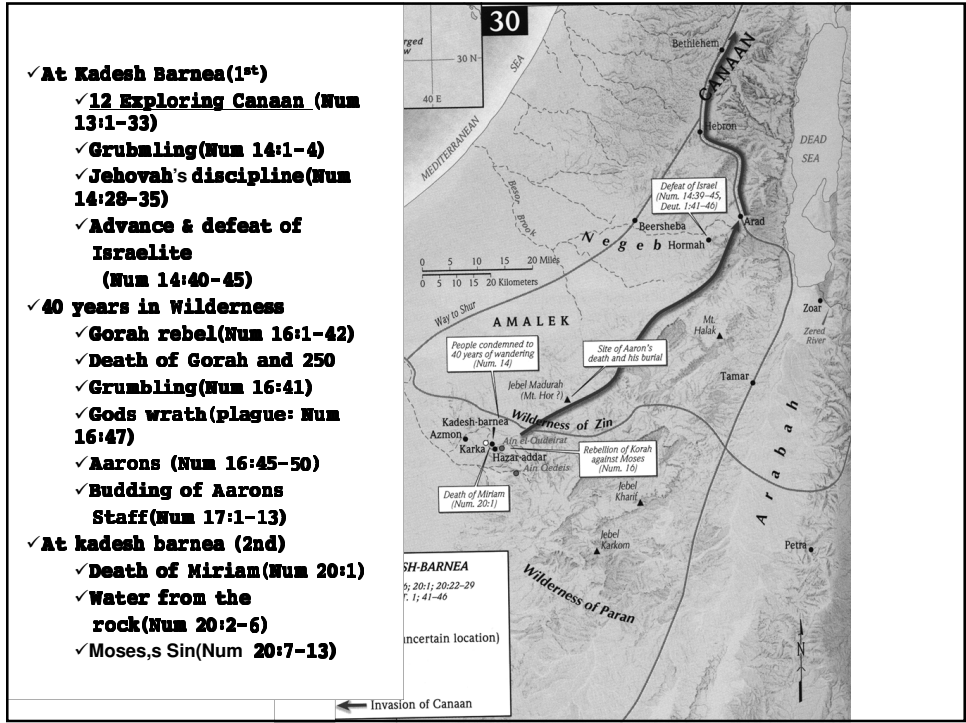

## Deuteronomy

- ✓ **1<sup>st</sup> Sermon(1:1-4:43)**
  - ✓ Reminiscence of 40 years of Wilderness
  - ✓ Journey from Mt. Horeb to Kadesh Barnea
- ✓ **2<sup>nd</sup> Sermon (4:44-28:68)**
  - ✓ Essence of Covenantal Faith (5:1-11:32)
  - ✓ Detailed covenant provisions (12:1-26:19)
- ✓ **3<sup>rd</sup> Sermon (29, 30)**
- ✓ **Last Days of Moses(31-34)**
  - ✓ Blessing
  - ✓ Death

[Master-map list](#)



## A Tale of 2 Generations

[Map master list](#)  
[Slides Main](#)

	The Exod. Generation	The Conquest Generation
Their Leader	Moses	Joshua
Commission from the Lord	In the Wilderness before the Exodus (Exod 3)	In the Wilderness Before crossing Jordan River (Jos 1:1-5)
God's Great Miracle	Parting the Red Sea (Exod 13)	Parting the Jordan River (Jos 3)
Place where the Law was given	Mt. Sinai (Exod 19-Lev 27)	The Plains of Moab (Deut 1:5)
Response of the people	Disobedience & Judgment in the wilderness	Obedience & Blessing in the Land (In Canaan)

## Blessing & Cursing (Deut 28)

<b>Blessings for Obedience</b>	<b>Disciplines for Disobedience</b>
<b>Victory from Enemies</b> (28:7)	<b>Defeat &amp; oppression by Enemies</b> (28:25-26, 30-35, 43-57)
<b>Prosperity in everyday life</b> (28:2-6, 8, 11-14)	<b>Ruin &amp; frustration in everyday life</b> (28:15-24, 27-29, 38-42, 58-63)
<b>Prominence among the nations</b> (28:1, 9-10)	<b>Exile to unknown lands</b> (28:36-37, 64-68)

## World



# To Promised Land Canaan

## Lecture 5

©The Bible Institute of Holy Land

[Map master list](#)  
[SlidesMain](#)

## Joshua

- ✓ **Purposes:**
  - ✓ A story about Yahweh who bring about victory through a people who follow His instructions.
  - ✓ Is to convey how Yahweh kept His covenant promise(He is faithful)
  - ✓ Is to bring the Israelites into the land He had shown to Abraham(He keeps His promises)

# Joshua

## Themes:

- **Covenant & Land**
  - **The fulfillment of the promised land was realized.**
- **The ban**
  - **Definition: Consecrate something or someone as a permanent and definitive offering for the sanctuary; in war, consecrate a city and its inhabitants to destruction; carry out this destruction; totally annihilate a population in war; kill**
  - **Make no treaty & show them no mercy (Deut 7:1-11, 20:10-18)**
  - **Joshua obeyed (Jos 6:17-19)**
  - **Reason : Wickedness of the people, Protect His people from the wicked people**
- **Sovereign Intervention**
  - **God fights**
  - **Miracle: Crossing Jordan(3), falling down of Walls of Jericho (6), Controls Victory and defeat(7:1f), Sun standing still(10:12-14)**
- **Corporate Solidarity(Jos 7)**
  - **Remember that you are a part of one**

# Joshua

- **Preparation for Conquest (1-2)**
- **Miracle Jordan River (3-4)**
- **Circumcision and Passover in Gial(5)**
- **Jericho and Ai 6-8)**
- **Deceived by Gebeonites (9)**
- **Conquest Southern region : Amorite 5 kings (10)**
- **Conquest Northern region: King of Hazor Yabin + (11)**
- **Allocation of the Tribes (13-19)**
- **Allocation of the Cities of Refuge and Levitical Cities(20-21)**
- **Controversy b/w East-West tribes(22)**
- **Final events of Joshua's life (23-24)**

## Purposes of Passover

- ✓ **Commemorated the physical redemption and rescue of the Israelite firstborn sons by the death of a substitute lamb.**
- ✓ **Reminded each person of his need for spiritual redemption from sin by substituting a slain lamb.**
- ✓ **Teaches us the significance of Christ's death—"the Lamb of God who takes away the sin of the world." (John 1:29)**

[Master-map list](#)  
[Slides Main](#)

# Conquest

## Lecture 6

©The Bible Institute of Holy Land

## 기본적 시대 변천

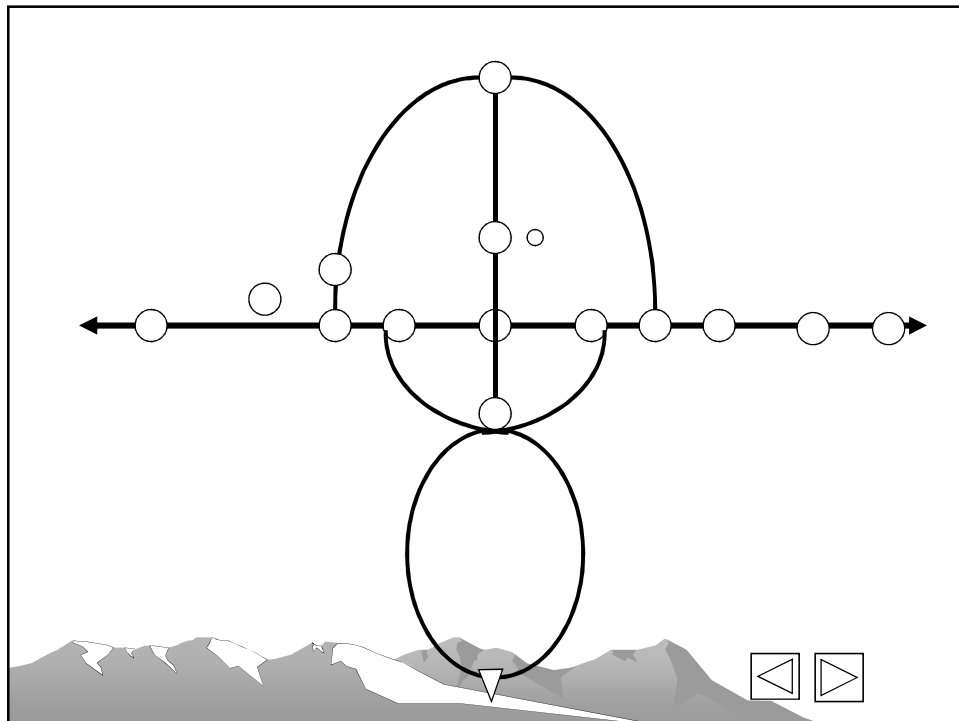
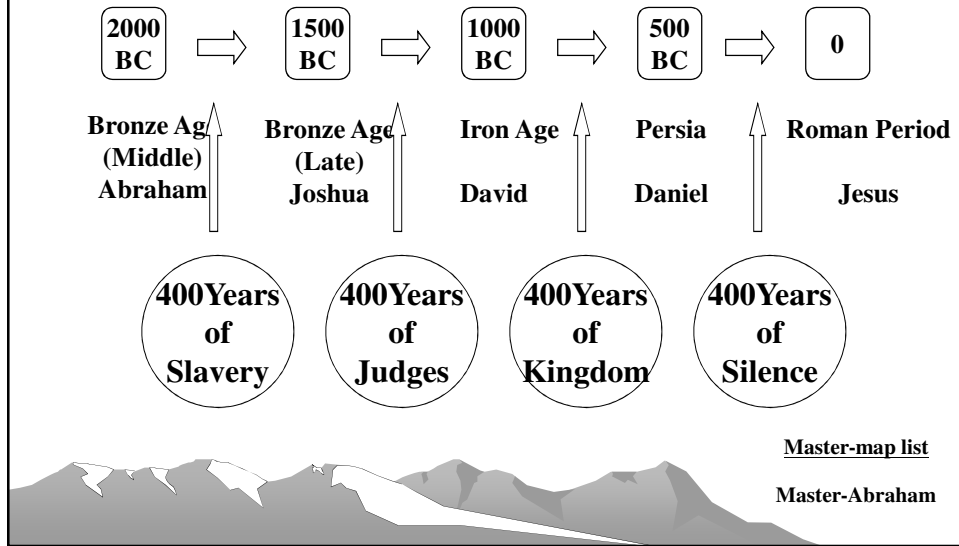

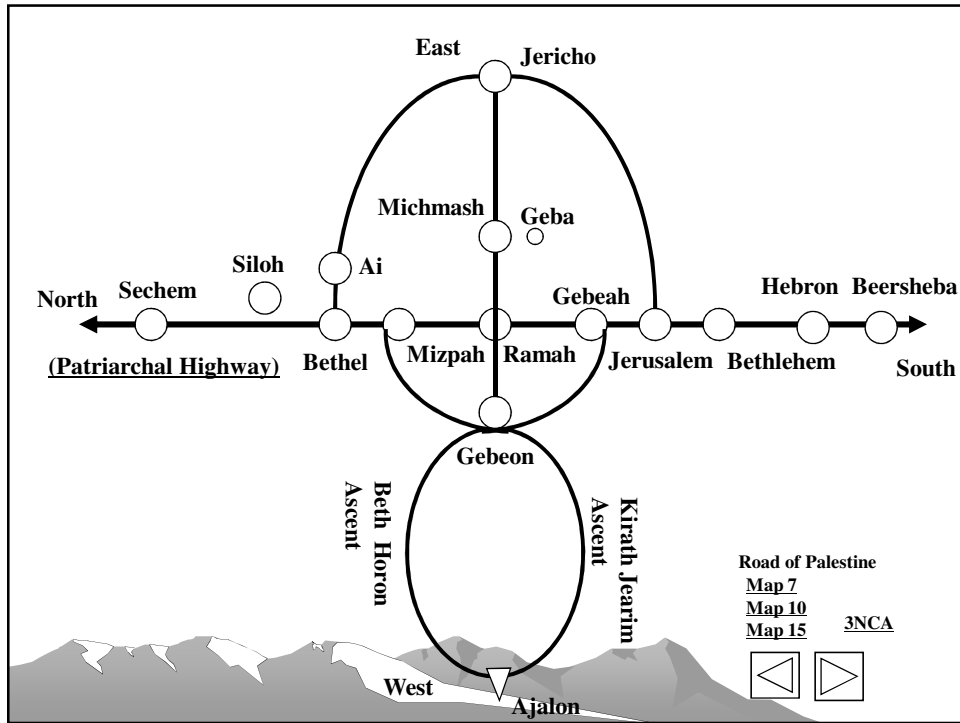

[Map master list](#)  
[Slides](#)  
[Main](#)

## Joshua

**Conquest:**

- **Central Region:**  
**Jericho, Ai, Bethel, Sechem**
- **Southern Region:**  
**Amorite 5 kings(Hebron, Yarmuth, Lachis, Eglon, Jerusalem)**
- **Northern Region:**  
**Hazor King Yabin and his alliances (@Merom)**

**Allocation of Tribes:**  
**12 Tribes (Excet Livites. Manasseh and Ephraim for Joseph)**



# Judges

## Lecture 7

©The Bible Institute of Holy Land

### Judges (1385-1055 B.C.)

- ✓ What was a Judge?
  - ✓ Primarily military role to stop foreign aggression against the nation
    - ✓ Advisory(Counsel) (Jud 4:4-5)
    - ✓ Judge
  - ✓ They did not seek to occupy a spiritual role.
    - ✓ Gideon (Jud 8:27: foreign worship)
    - ✓ Jephtha (Jud 11:30-40: child sacrifice)
    - ✓ Samson (Jud 14-16: Cavorting w/ woman)

- ✓ Task: to deliver the nation

[Slide master list](#)

[Map master List](#)

## Israel's Apostasy

- **How could Israel have strayed so far?**
  
- **The problem?**
  - **Failure to completely conquer Canaan**
    - ✓ (Jud 1:19, 22, 27, 29, 30, 31, 33, 34-36)
  - **Failure to destroy Canaanite religion**
    - ✓ (Jud 2:11-13)
  
- **The result ?**
  - **Jud 2:10-23**

[Slide master list](#)

[Map master List](#)

## Judges

- **Israelites did evil in the eyes of the Lord and served Baal**
  - **2:11; 3:7; 4:1; 6:1; 10:6; 13:1**
  - cf. **신 12:8-12**
- **In those days Israel has no king; everyone did as he saw fit**
  - **17:6; 21:25 (18:1; 19:1)**

[Slide master list](#)

[Map master List](#)

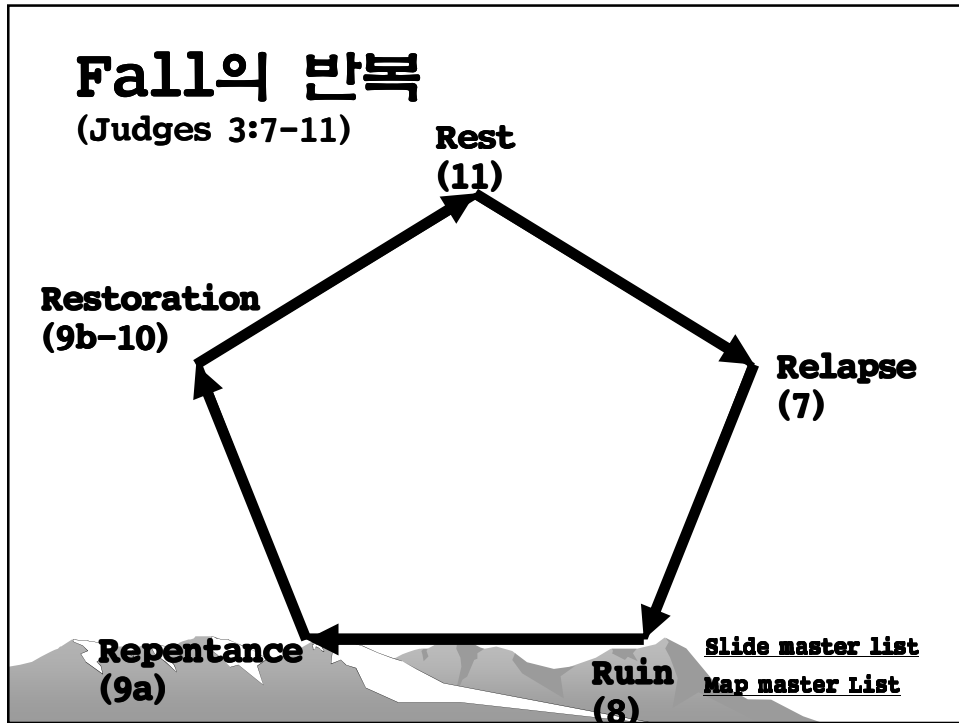

- ## Judges
- [Slide master list](#)  
[Map master List](#)
- **Coexistence with Canaanites (Jud 1)**
  - **Theme of the Judges (Jud 2:11-19):**  
Apostasy → Restoration
  - **Judges (3-16)**
    - Othiel, Ehud, Shamgar (3)
    - Deborah (4)
    - Gideon (6-8)
    - Tola, Jair, Jephthah, Ibzan, Elon, Abdon (10-12)
    - Samson (13-16)
    - **Theme of Judges (Jud 2:11-19)**
  - **Depravity (17-21)**
    - Mica & Dan (17-18)
    - Gebeah incident (19-21)

## A postscript in Chapters 17-21

- **Example of Spiritual Decline**
  - **Apostasy of Dan (Jud 17-18)**
- **Example of Moral Decline (Jud 19-21)**
  - **The sordid story of Gibeah & near extermination of Benjamin**

Slide master list

Map master List

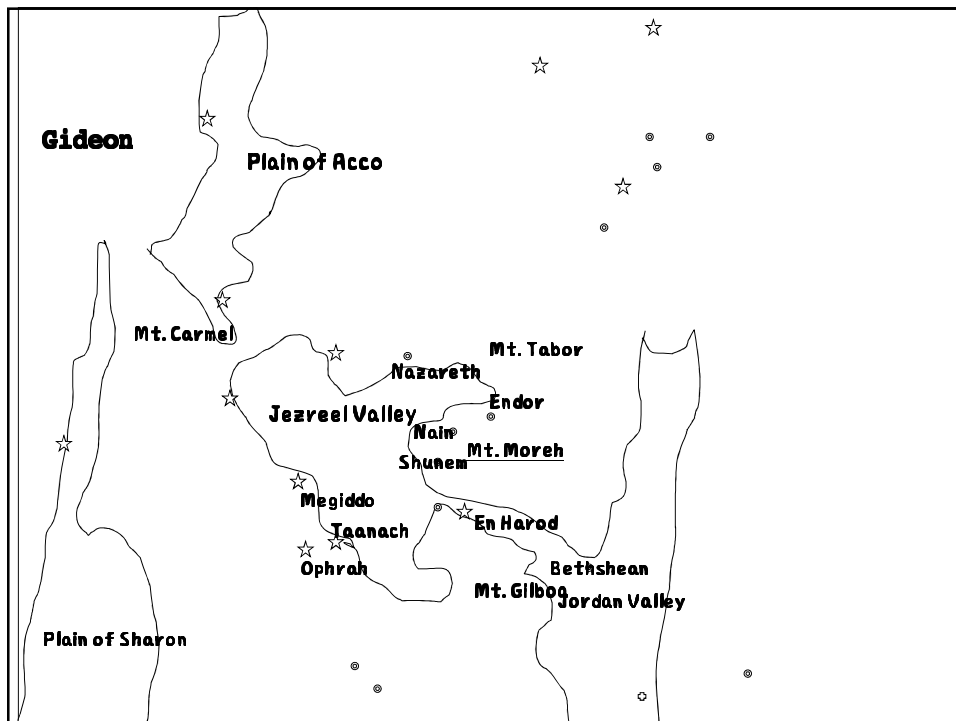

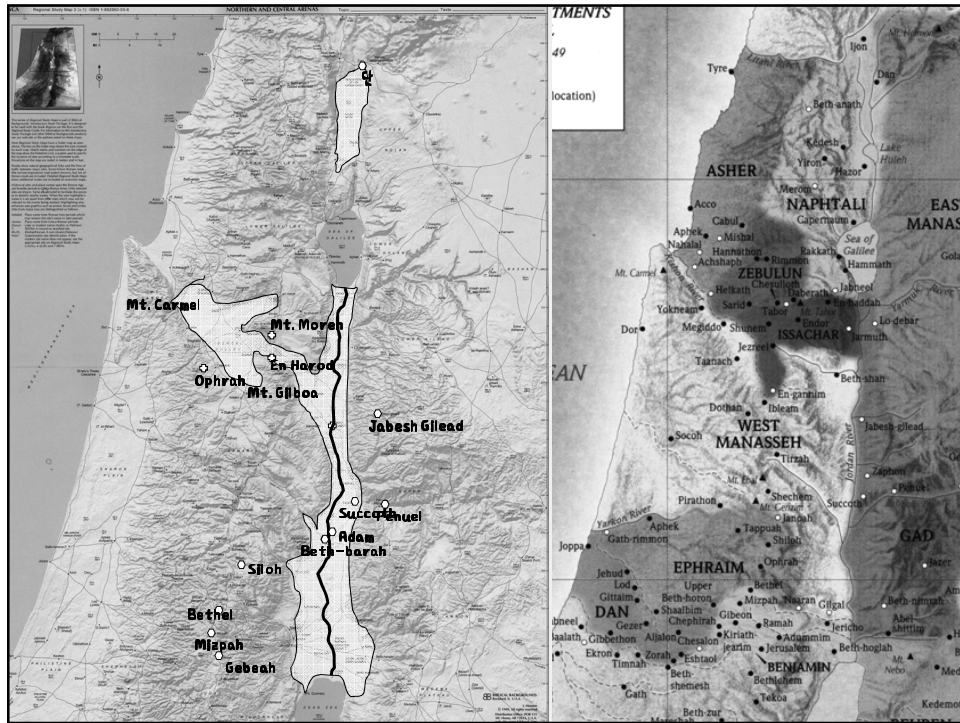

## Ruth

- ✓ **Ruth is an example of godly woman and godly Gentiles who were instrumental in His plan**
- ✓ **Provides the geneology of David and Messiah**
- ✓ **God's faithfulness**

**Slide master list**

**Map master List**

## Kinsman-Redeemer?

- ✓ **Deut 25:5-10; If a man dies and has no son, the brother was obliged to bear a son by his widow to maintain an heir**
- ✓ **Lev 25:25-31, 47-55**
- ✓ **The Kinsman-redeemer provides the means to redeem or buy back what was lost (Christ)**

[Slide master list](#)

[Map master List](#)

## Christ & Boaz

<b>Christ</b>	<b>Boaz</b>
<b>Human race</b>	<b>Kinsman</b>
<b>Payment of our death</b>	<b>Paying debts of widow</b>
<b>Bridegroom+Bride Christ+Church</b>	<b>Bridegroom + Bride Boaz+Ruth</b>

[Slide master list](#)

[Map master List](#)

# Unified Kingdom

## Lecture 8

©The Bible Institute of Holy Land

[Slide master](#)  
[Map master](#)

## Kingdom

- 1 Sam: Samuel → Death of Saul
- 2 Sam: Death of Saul → Araunah' s Threshing floor
- 1 Kings: Old David → Death Ahab & Jehozabad
- 2 Kings: Death of Ahab → Judah' s King Zedekiah
- 1 Chr: Adam' s Geneology → Death of Davit
- 2 Chr: Solomon → Fall of Jerusalem, Exile & Return

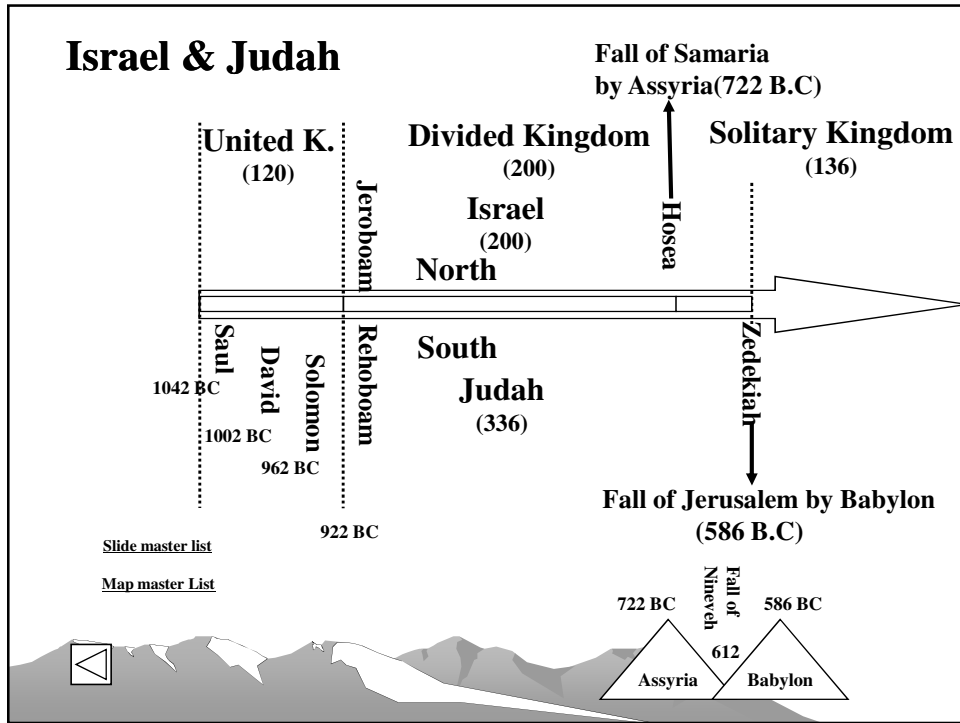

## Samuel

[Slide master](#)  
[Map master](#)  
 M-연약권 ■ 웃길

- ✓ Last Judge (1 Sam 7:15)
- ✓ Priest
- ✓ Prophet
- ✓ The begging of the theocratic Kingdom



## The ark of God was captured

(1 Sam 4-6)

- ✓ Eli and his sons
- ✓ Aphek and Ebenezer
- ✓ The ark of the Lord came into the camp
- ✓ Captured
- ✓ Ashdod, Gath, Eglon
- ✓ Cart with 2 cows
- ✓ Beth Shemesh
- ✓ Kiriath Jearim (Eleazar in the house of Abinadab)



## Qualifications for Israel King

(Deut 17:14-20)

[Slide master](#)  
[Map master](#)

- ✓ Chosen by God
- ✓ a Hebrew , not a foreigner
- ✓ Not to emphasize military power  
(do not go to Egypt to get horses)
- ✓ Not to take many wives
- ✓ Not to seek great wealth
- ✓ To possess his personal copy of the Law,  
Study it carefully, and obey it
- ✓ He is to be a humble man



## Saul

Jabesh Gilead 전투  
3.NCA(PLAIN)

- ✓ Benjaminite
- ✓ Samuel anoints Saul→Leader (1 Sam 10:1)
- ✓ Chosen as a King in Mizpah (1 Sam 10:24)
- ✓ War against Ammon in Jabesh Gilead (1 Sam 11:1-11)
  - ✓ Establish his kingship
- ✓ Disobedience
  - ✓ Burnt offering in Gilgal: (1 Sam 13:8-14)
  - ✓ War against Amalekites (1 Sam 15:3)
- ✓ Result (1 Sam 15:28)
  - ✓ Has given it to one of your neighbors—to one better than you

## David

Slide master  
Map master

- ✓ David was chosen(1 Sam 16:1, 12-13)
- ✓ Kills Goliath (1 Sam 17)
- ✓ Jealousy of Saul(1 Sam 18-19)
- ✓ Friendship of David & Jonathan (1 Sam 20)
- ✓ David's Flight (1 Sam 21-30)
  
- ✓ Counter attack to Amekites(1 Sam 30)
- ✓ Death of Saul(1 Sam 31)

## David

[Slide master](#)  
[Map master](#)

- ✓ Anointed in Hebron as King of Judah(2 Sam 2:4)
- ✓ David's Hebron←→Ishbosheth's Mahanaim
- ✓ Establishment of Kingship (2 Sam 5)  
(Abner & Joab)
  - ✓ became a king of Israel(5:3)
  - ✓ Conquest of Jerusalem(5:6-9)
  - ✓ Victory over Philistine(5:17-25)
- ✓ Bring the ark of Lord to Jerusalem (2 Sam 6)
- ✓ Davidic Covenant (2 Sam 7)
- ✓ Expanded Israel border (2 Sam 8)
- ✓ Keep his promise with Jonathan(2 Sam 9)
- ✓ Victory over Ammon(2 Sam 10)

## David

- ✓ David's sin, discipline, repentance (2 Sam 11:1-12:23)
- ✓ Consequences from the sin(Disaster: 2 Sam 12-17)
  - ✓ Death of his son
  - ✓ Amnon and his sister Tamar
  - ✓ Absalom kills his brother Amnon
  - ✓ Revolt by Absalom
  - ✓ David's defection: Jerusalem→Mahanaim
  - ✓ Absalom sleeps with David's concubines
- ✓ Restoration (2 Sam 18:15-22:51)
  - ✓ Death of Absalom, Return to Jerusalem
  - ✓ David's compassion, rewards and punishments
    - ✓ Shimei, Mephibosheth, Barzillai, Gebeonites,
  - ✓ David's Victory over all enemies
- ✓ David's Census(2 Sam 24)
  - ✓ God's Punishment
  - ✓ Threshing floor (Arauna)

[City of David](#)

[Slide master](#)  
[Map master](#)

# Solomon

[Slide master](#)  
[Map master](#)

## ✓ Early Years

- ✓ Loved by Yahweh(2 Sam 12:24-25)
- ✓ Wisdom (1 Ki 3)
- ✓ Brought Peace, Prosperity, Wealth,  
Gloryfication to Israel(1 Ki 10:14-29), Temple  
construction (1 Ki 6:1-7:12), Learn art and  
sciences (1 Ki 4:29-34)



# Solomon

[Slide master](#)  
[Map master](#)

## ✓ Later:

- ✓ Politically decline
- ✓ Spiritually corrupted
- ✓ Reasons:
  - ✓ Interracial Marriage (cf. Prob 5:1-4; 7:6-27)→Idol Worship(1 Ki 11:1-3; cf. 3:3)
  - ✓ Alliance with Foreign country thru marriage  
(1 Ki 3:1-2)
  - ✓ Syncretism(1 Ki 11:1-8)
  - ✓ Trade  
(1 Ki 9:26-28; 10:22-24)
- ✓ Consequence
  - ✓ I will most certainly tear the kingdom  
away from you and give it to one of  
your subordinates.  
(1 Ki 11:10-12)



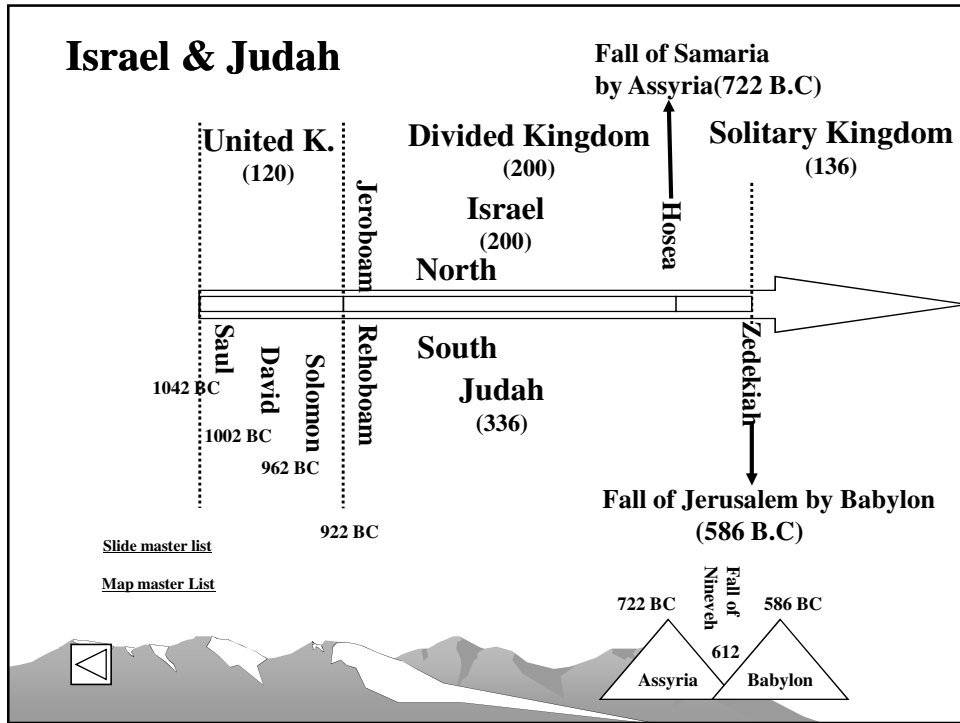

# Divided Kingdom

## Lecture 8

©The Bible Institute of Holy Land

# 바알 숭배의 유입

Slide master  
Map master

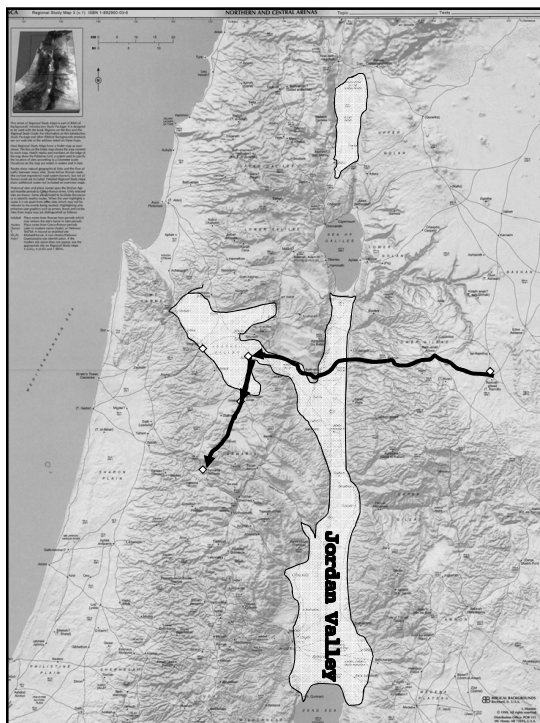
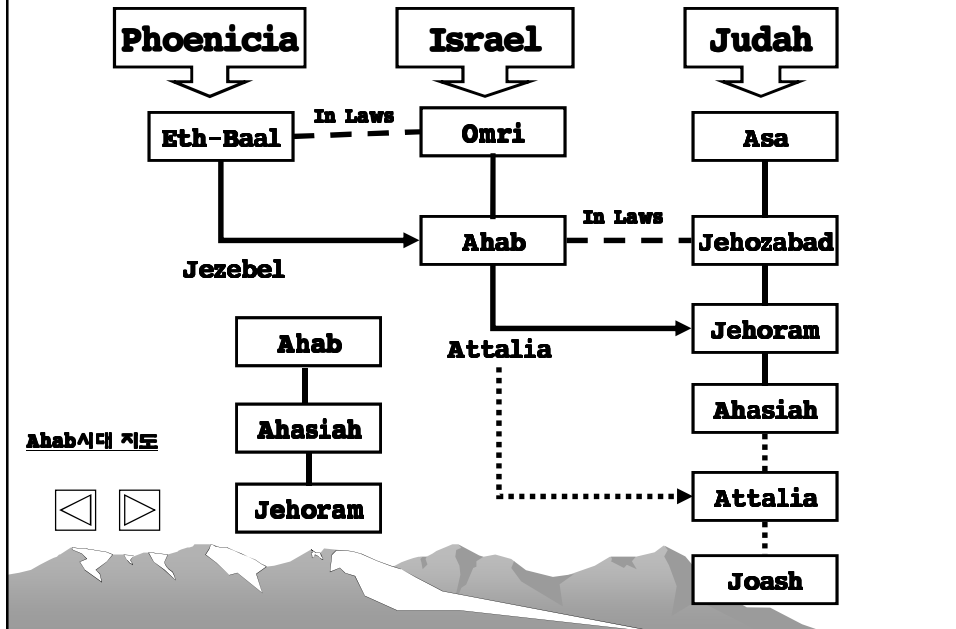

## Jehu (2 Kings 9:3 - 10:27)

### Jehu Dyansty(5 Kings)

Jehu → 여포아하스

→ Joash →

Jeroboam

2세 → Zechariah



# Fall of Israel and Judah

## Lecture 9

©The Bible Institute of Holy Land

### Fall of Israel and Judah

#### **Israel**

**During Hosea by King of Assyria  
Salmaneser**

**(2 Kings 17:1-6, 22-41)**

**Brought People from Babylon, Cutha,  
Avva, Hamath, Sepharvaim (Map)**

#### **Judah:**

**During Zedekiah by King of Babylon  
Nebuchadrezzar**

**(2 Kings 25:8-12, 대하 36:11-20, Map)**

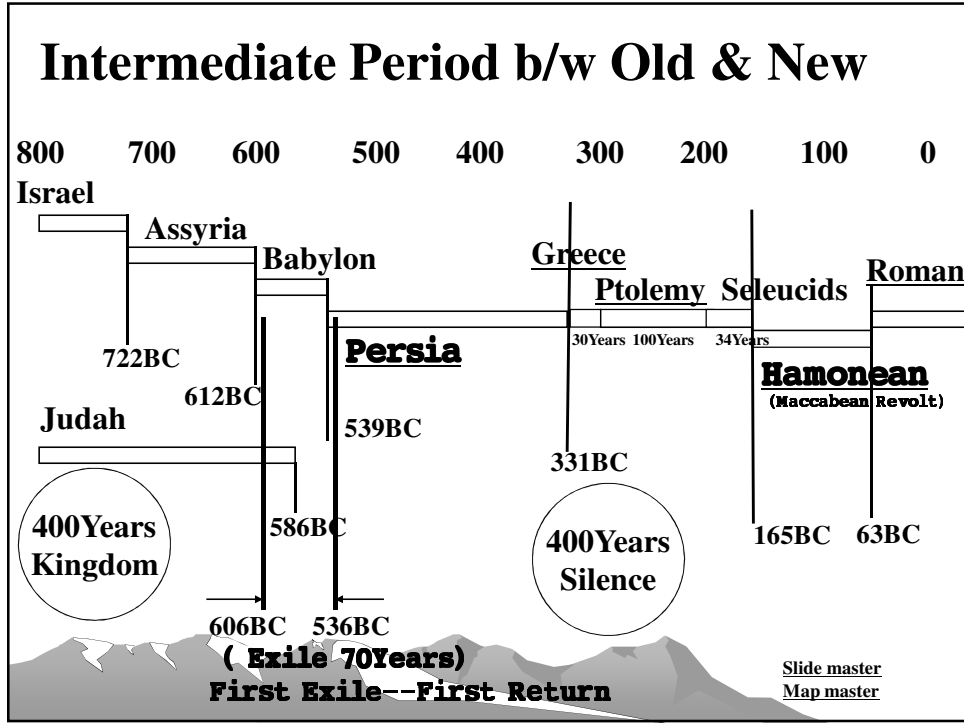

# Exile & Return

## Lecture 10

©The Bible Institute of Holy Land



## Exile

### Babylonian Kings :

**Nebuchadnezzar (606-562 BC)**

**First Exile (Daniel) 606 BC**

**Second Exile (Ezekiel) 597 BC**

**Third Exile (fall of Jerusalem) 586 BC**

**Belshazzar (553-539 BC)**

**Fall of Babylon (539 BC)**

### Persian Kings:

**Cyrus (539-530 BC)**

**1st Return(537): Zerubbabel & Jeshua**

**Haggai & Zechariah**

**Ahasuerus (486-465 BC) : Esther**

**Artaxerxes (465-425 BC)**

**2nd Return(457): Ezra**

**3rd Return(445): Nehemiah**



## Exile & Return

[Slide master](#)

[Map master](#)

(586-400 BC)

### ✓Prophets

#### ✓Jeremiah (Judah):

✓Obey God's Punishment thru  
Babylon

✓Return after 70 years: Jer 25:11f

#### ✓Ezekiel (Babylon, Chebar):

✓God's glory departing from  
Jerusalem

✓Return of God's glory to Temple

#### ✓Daniel (Babylon):

✓God's sovereignty over men and  
nations



# 70Years of Exile

[Slide master](#)  
[Map master](#)

✓ 2 Chr 36:21

**God compulsively enforce Sabbath**

Lev 25:1-7

**one year at 7th Year should be Sabbath year**

**70Years of exile x 7 = 490 Years**

**606 BC First Exile**

**- 536 BC First Return**

**70 Years (Jer 25:11ff)**

**586 BC Destruction of Temple**

**- 516 BC Reconstruction**

**70 Years**



# Return

[Slide master](#)  
[Map master](#)

Leader	Zerubbabel (Sheshbazzar)	Ezra	Nehemiah
Year	537 (536)	457 (458)	445 (444)
Word	Ezra 1-6	Ezra 7-10 Neh 8-12	Neh 1-7, 13
Return	50,000	2,000	A Few
Purpose	Temple	worship	Jerusalem Wall
Problem	Samaritan	Interracial Marriage	Samarians



# 예언서의 위치

Slide master  
Map master

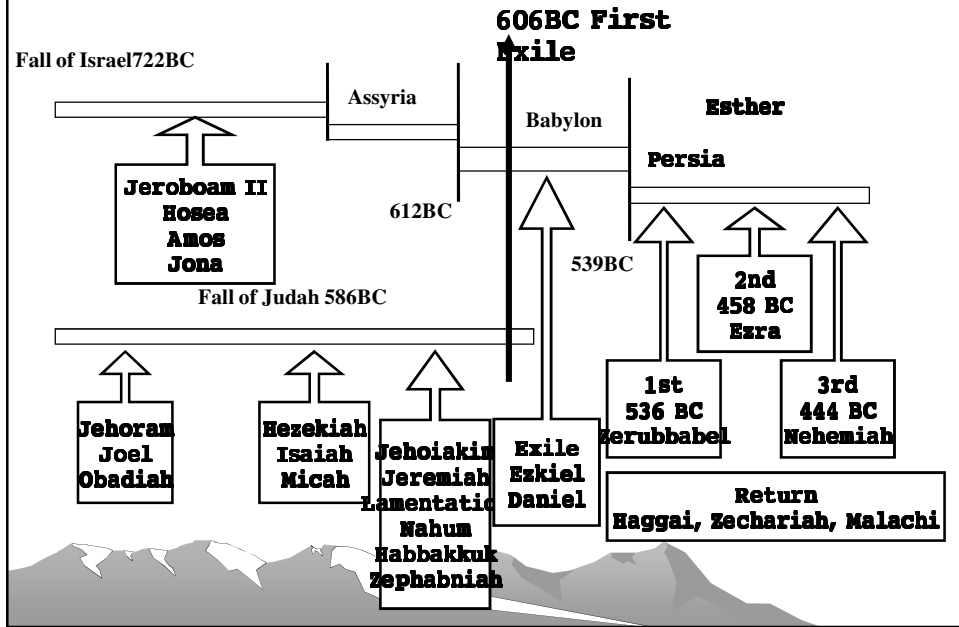

# 신구약 중간기

©The Bible Institute of Holy Land

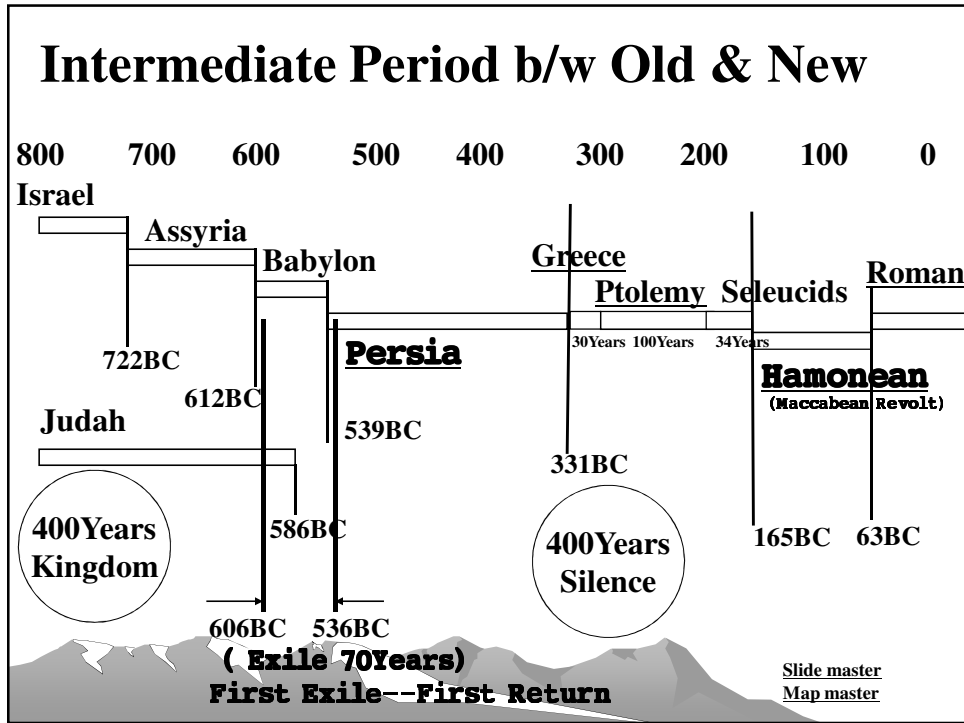

## 신구약 중반기

Slide master  
Map master

- **Persia( 539-331BC)**  
Cyrus, Ahasuerus, Artaxerxes
- **Greece( 331-165BC)**  
Alexander and his followers(DIADOCHI)  
Ptolemy+Seleucids+....+...
- **Hebrew Indepence (165BC-63)**  
Maccabeo Revolt (168-143BC)  
**Hamonean (142-63BC):**Antipas was installed as Idumean Procurators
- **Roman (63-62BC → AD70)**  
Antpaeter → **Herod the Great**

**Archelaus Philip Antipas**  
**(Judea+Samaria+Idumea) (Galilee+Perea)**

# Gospels & Jesus

## Lecture 11

구약복음

©The Bible Institute of Holy Land

### Old Testament prophecies about Messiah

[Slide master](#)  
[Map master](#)

- ✓ 2 Sam 7:12-13
  - ✓ Establish nation thru David's Descendants
  - ✓ Establish the throne of his kingdom forever
- ✓ Isa 7:14
  - ✓ Signs given to Israel:  
Virgin will give birth to a son
  - ✓ Immanuel(His Name)
- ✓ Isa 53:3-7
  - ✓ Oppressed, afflicted and died
  - ✓ Innocent w/o sin but die like a lamb
  - ✓ Punished for our sin
- ✓ Mic 5:2-5
  - ✓ Born in obscure Bethlehem Ephrathah
  - ✓ Rule over Israel and worldwide

# Gospels

<b>Matthew</b>	<b>Mark</b>	<b>Luke</b>	<b>John</b>
<b>Jewish Christians</b>	<b>Romans</b>	<b>Greeks</b>	<b>All Mankind</b>
<b>King of Israel</b>	<b>Servant of Jehovah</b>	<b>Son of Man</b>	<b>Son of God</b>
<b>Long Discourses</b>	<b>Miracles</b>	<b>Parables</b>	<b>Personal Interviews</b>



# Jesus's Geneology

## ✓Matthew(Joseph)

- ✓41 names from Abraham
- ✓Messiah
- ✓Jewish
- ✓5 women

## ✓Luke(Mary)

- ✓74 names from Adam
- ✓Jesus is Son of a Man
- ✓Jesus's human nature
- ✓No woman



# Jesus's Geneology

[Slide master](#)  
[Map master](#)

## ✓Mark

✓No geneology necessary

✓Roman Period

✓Jesus as a Servant of God

## ✓John

✓In the beginning was Word  
(John 1:1, 14)

✓Jesus is God

✓Jesus's divine nature



# Life of Jesus

## Lecture 12



©The Bible Institute of Holy Land

# Life of Jesus

[Slide master](#)  
[Map master](#)

- ❖ Birth & Early Years
- ❖ Childhood
- ❖ Public Life
- ❖ 3 1/2 Years



## Life of Jesus & Political Background

[Slide master](#)  
[Map master](#)

BC. ←                      ⇒ AD.  
4    0    4    8    12    16    20    24    28    32    36    40    44

**Jesus**  
**Early Years(12Years)**                      **Public Life**

<b>Herod the Great</b> <small>(BC 37-4)</small>	<b>Archelaus</b>	<b>Roman Procurators</b>	<b>Pilate</b>	<b>Judea</b>
				<b>Galilee</b>
	<b>Antipas</b>			<b>Perea</b>
	<b>Philip</b>			<b>Iturea Trachonitis</b>

Jesus Early Years 지도  
Jesus 당시 Israel 지도





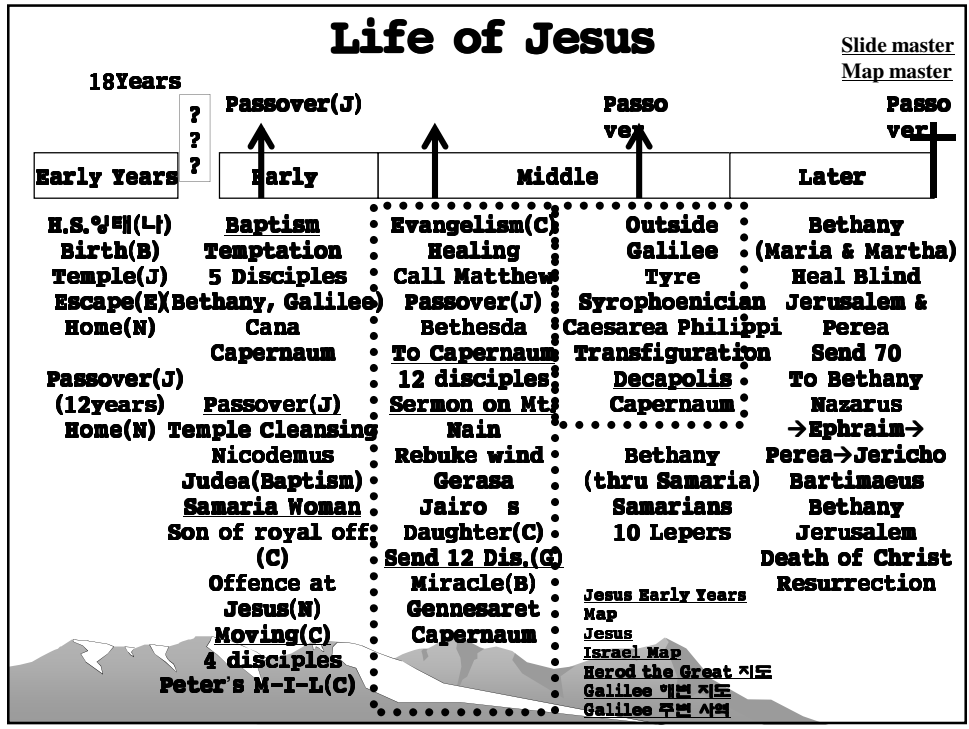

# Last Week

## Lecture 13

©The Bible Institute of Holy Land

## Last Week of Jesus

Slide master  
Map master  
M-마지막 주간  
갈바산  
식부리는 비유장소  
Bethany

### Saturday:

- ✓ Bethany (Arrival)

### Sunday:

- ✓ Entering Into Jerusalem
- ✓ Sat on the colt at Bethphage(Matt 21:1-7)
- ✓ Hosanna(Oh, save us)(Matt 21:9)
- ✓ Back to Bethany

### Monday:

- ✓ Temple cleansing  
(Mark 11:15-18; Luke 19:45-48; Matt 21:12-13)
- ✓ Religious leaders begin looking for a way to kill (Mark 11:18)

### Tuesday:

- ✓ Debate w/Religious leaders in the Temple  
(Matt 21:15-18; 23-46; 22:15-46)
- ✓ Widow's LEPTON (Luke 21:1-4)
- ✓ Teaching about the Last time at Mt. Olive  
(Matt 24; Mark 13)

## Last Week of Jesus

Slide master  
Map master  
M-마지막 주간

### Wednesday:

- ✓ Silently at Bethany
- ✓ Possibilities:
  - ✓ A woman pouring perfume at Simon's house (Leper)(Mark 14:3-9; Matt 26:6-13)
  - ✓ Judah plots w/Priests —Conclusion  
(Matt 26:14-16)

### Thursday:

- ✓ Passover supper at the upper room (마 22:14-20)
- ✓ Gethemane (Matt 26:36-45; Mark 14:32-42)
- ✓ Judah+High Priest+Captains of the Temple+Elders Seize Jesus  
(Luke 22:47-53, John 18:2-12)
- ✓ Caiaphas House (Matt 26:57-75; John 18:12-23)



## Last Week of Jesus

Slide master  
Map master  
▶-마지막 주간

### Friday:

- ✓ Sanhedrin@Temple⇒death(Luke 22:66)
  - ✓ To Pilate (for approval: Mark 15:1-5; Luke 23:1-5)
  - ✓ To Herod (Galilean, Luke 23:6-12)
  - ✓ Back to Pilate
  - ✓ Pilate sentence Death to Christ ⇒Golgotha
- Death of Christ**

### Saturday: (Sabbath)

### Sunday:

- ✓ Resurrection
  - ✓ Jerusalem (Matt 28:9-10; Mark 16:14-18; John 20:19-29)
  - ✓ Road to Emmaus (Luke 24:13-35)

### 40 days later:

- ✓ Ascension
    - ✓ At Mt Olive (Acts 1:9-11; 막 1:19)
- “Will come back in the same way”**

## Last Day(전천Years실): Futuristic View

Slide master  
Map master

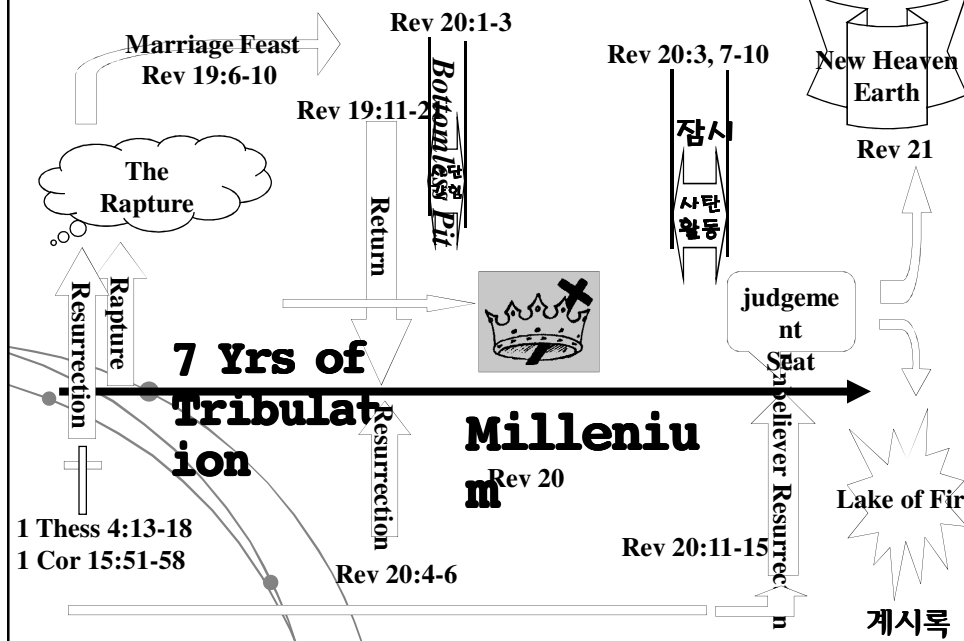

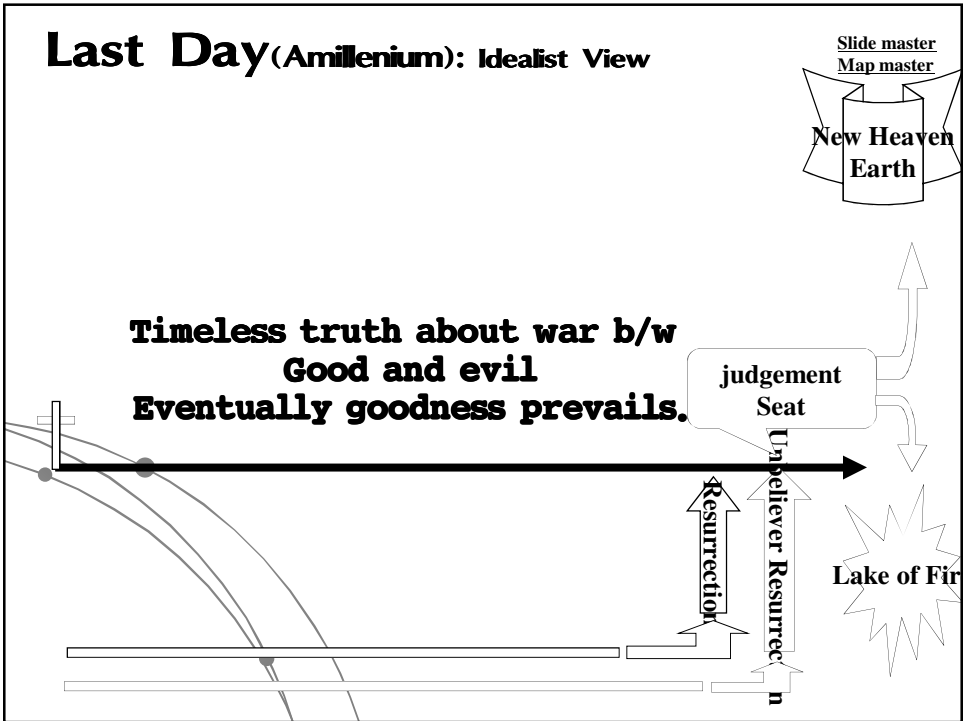
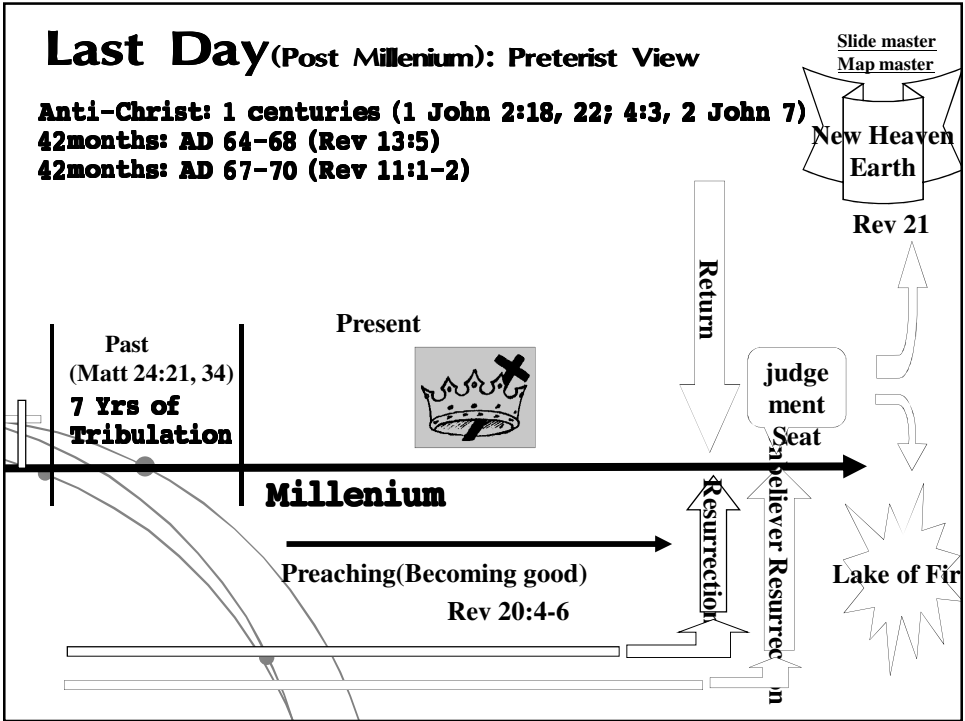

# Holy Spirit & Gospel

## Lecture 14

©The Bible Institute of Holy Land

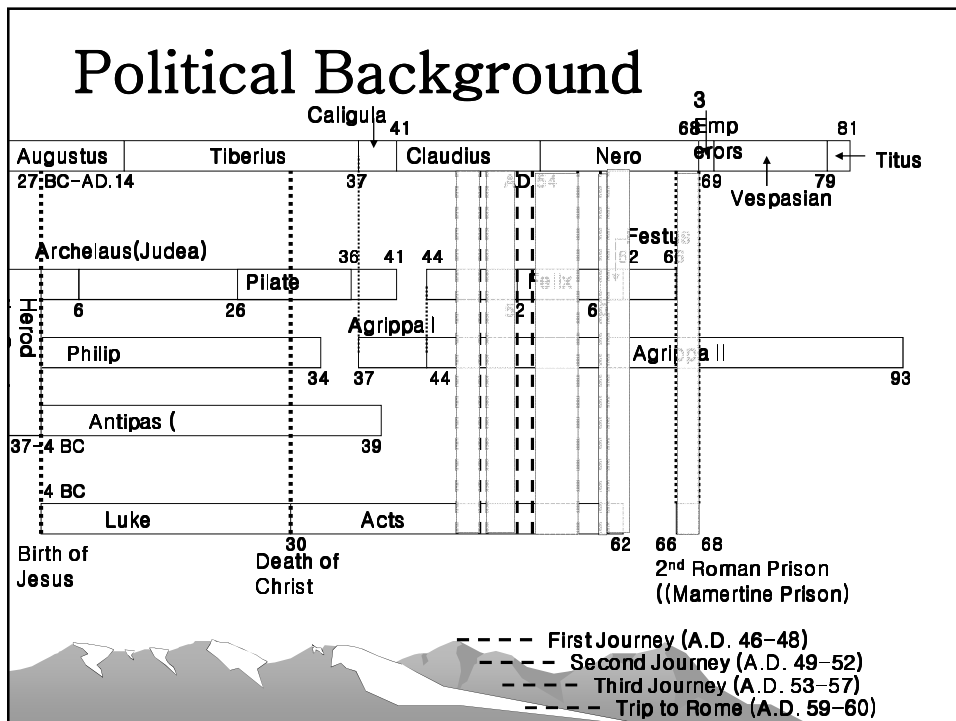

# Acts 2:9-12

Acts 1:8

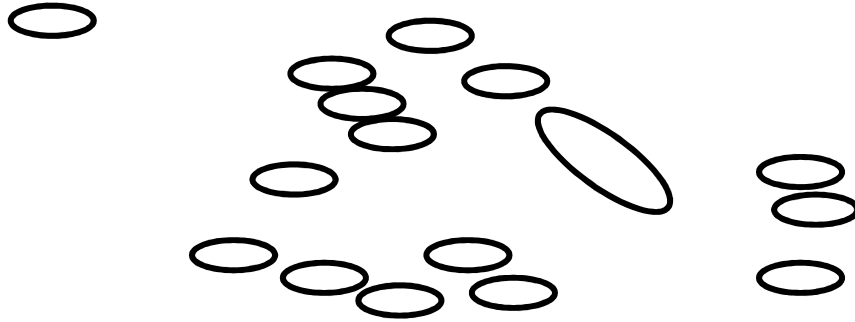

## Jerusalem 과 Judea와 Samaria 사역 (Acts 2-8)

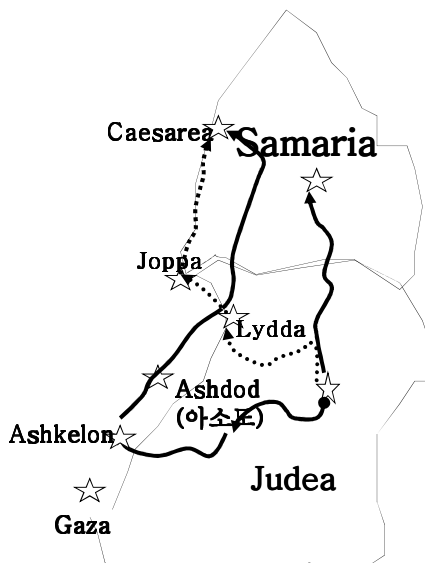

Jerusalem  
Samaria  
Ashkelon  
Caesarea

Scattered throughout Judea and Samaria(Acts 8:1)

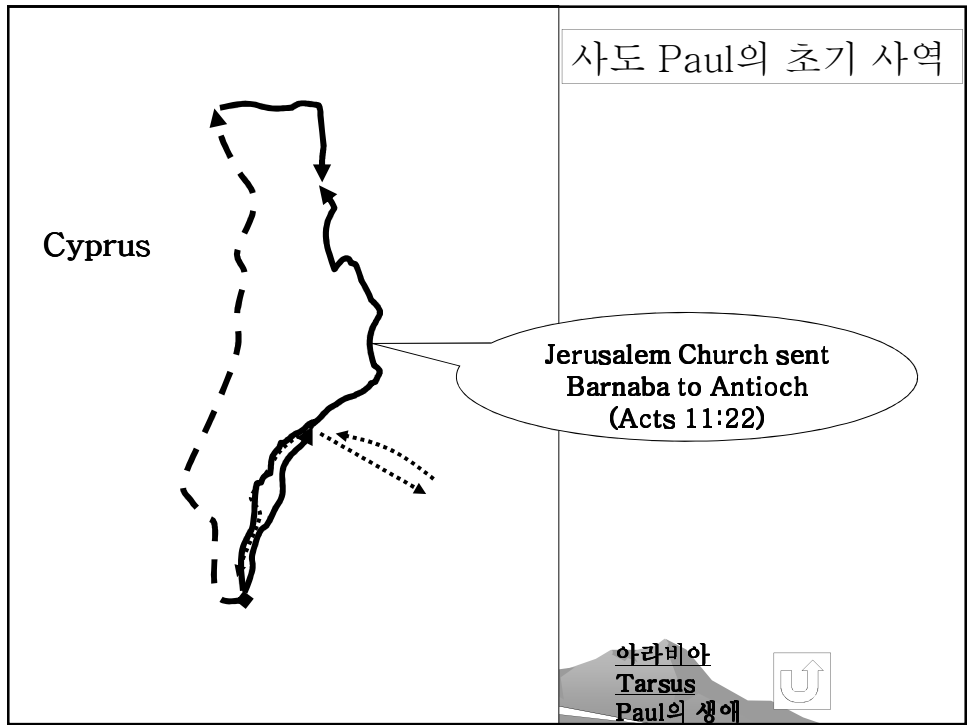
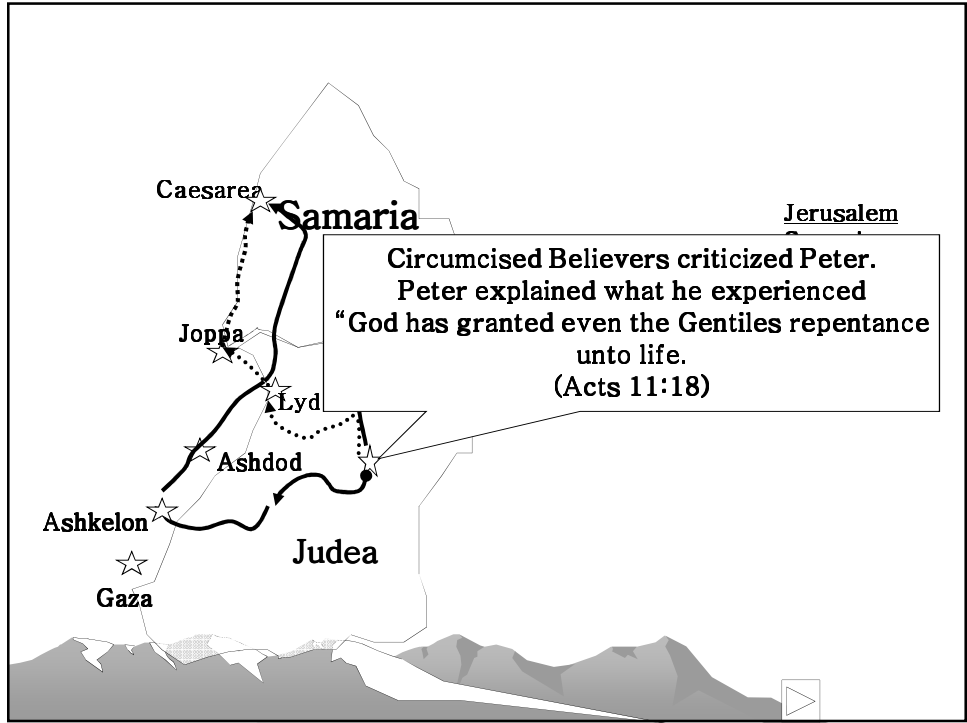

# Paul 1<sup>st</sup> Journey

## Lecture 15

©The Bible Institute of Holy Land

### *Paul's Missionary Journey*

- 1st: 『Acts 13:4 .....14:28』
- 2nd: 『Acts 15:39 .....18:22』
- 3rd: 『Acts 18:23 .....21:14』
- Confinement:  
『Acts 21:33 .....2b:32』
- Roma: 『Acts 27:1 .....28:31』



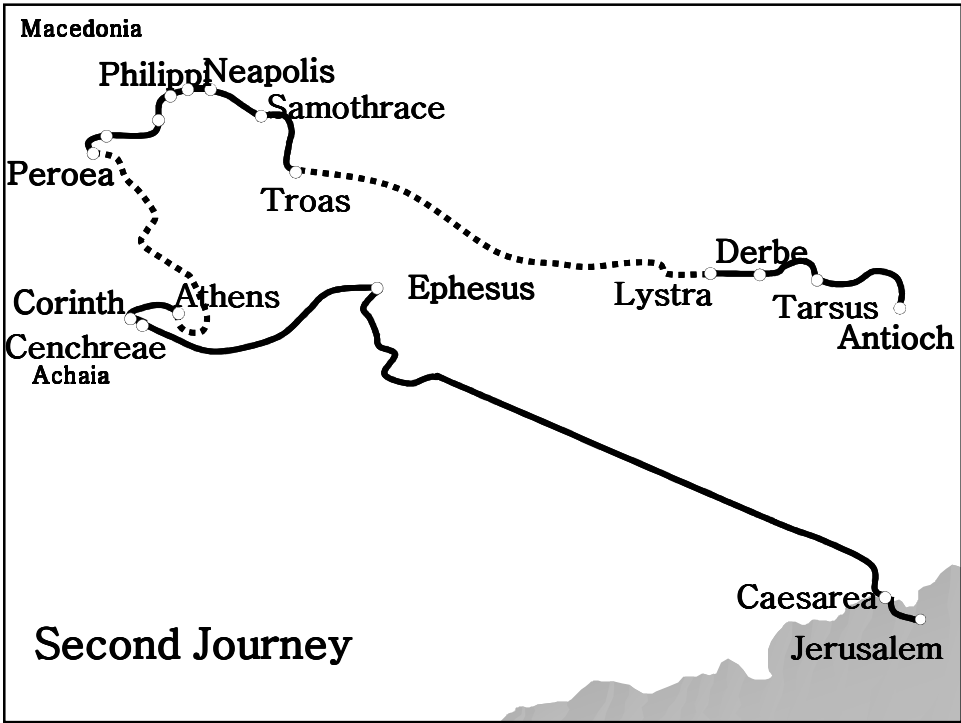
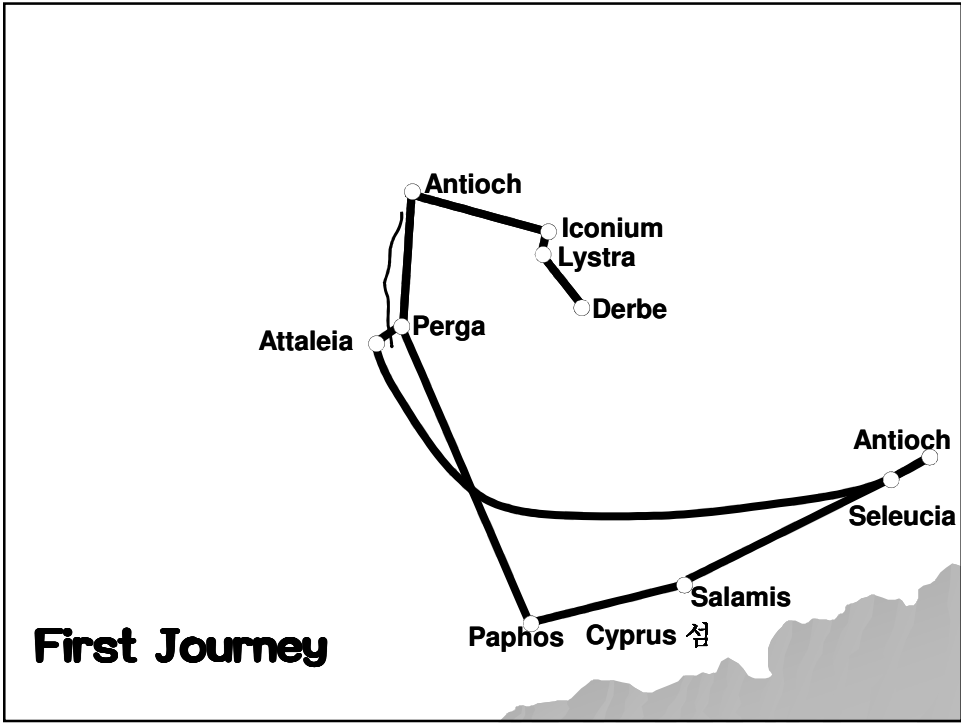

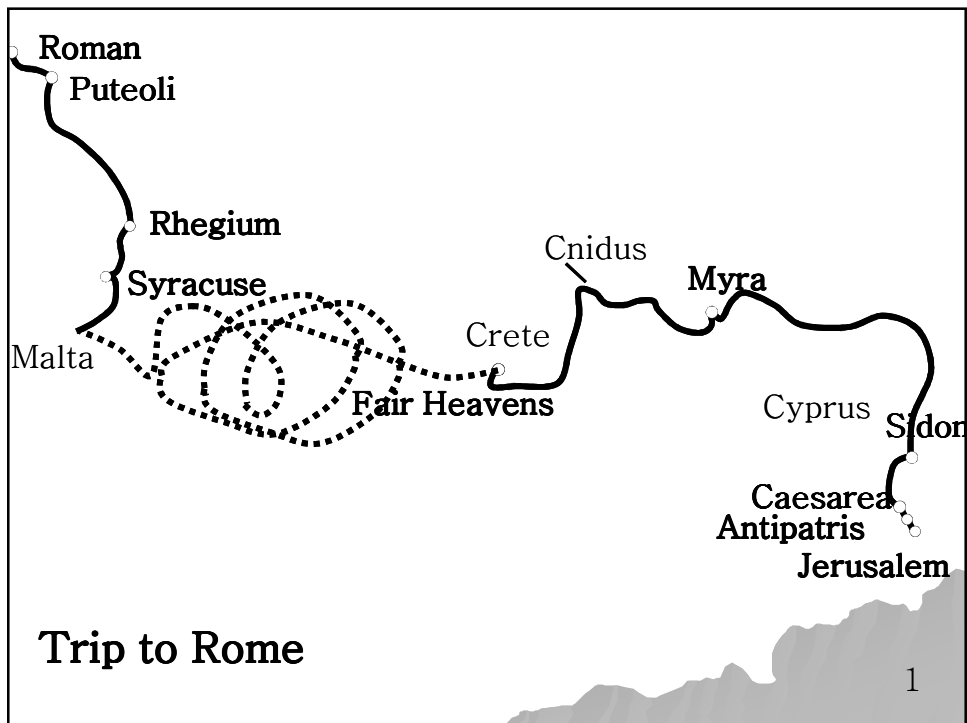
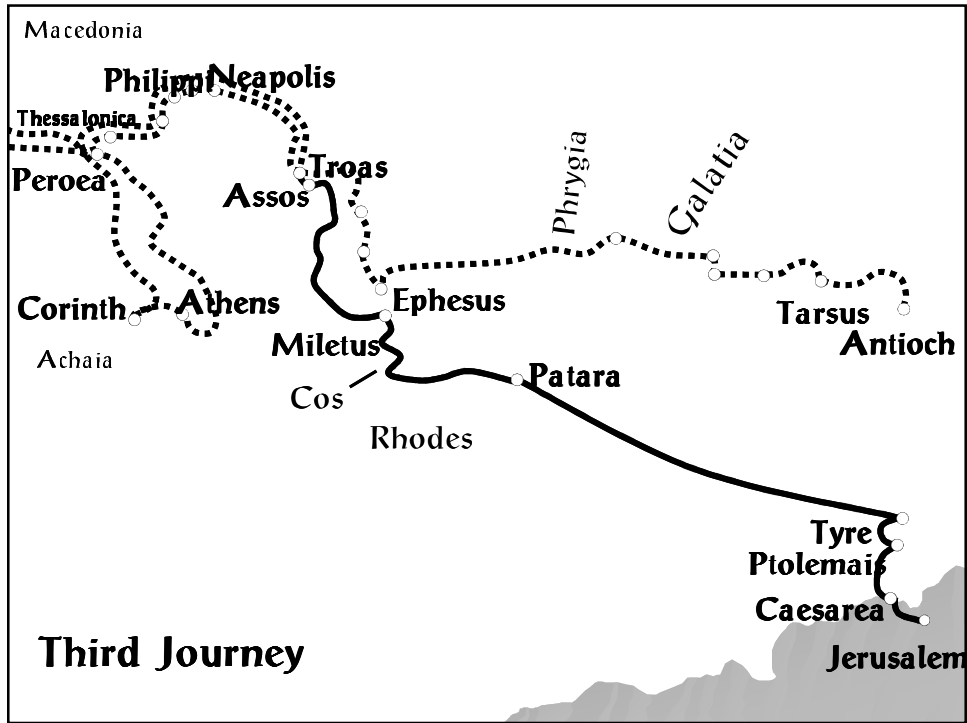

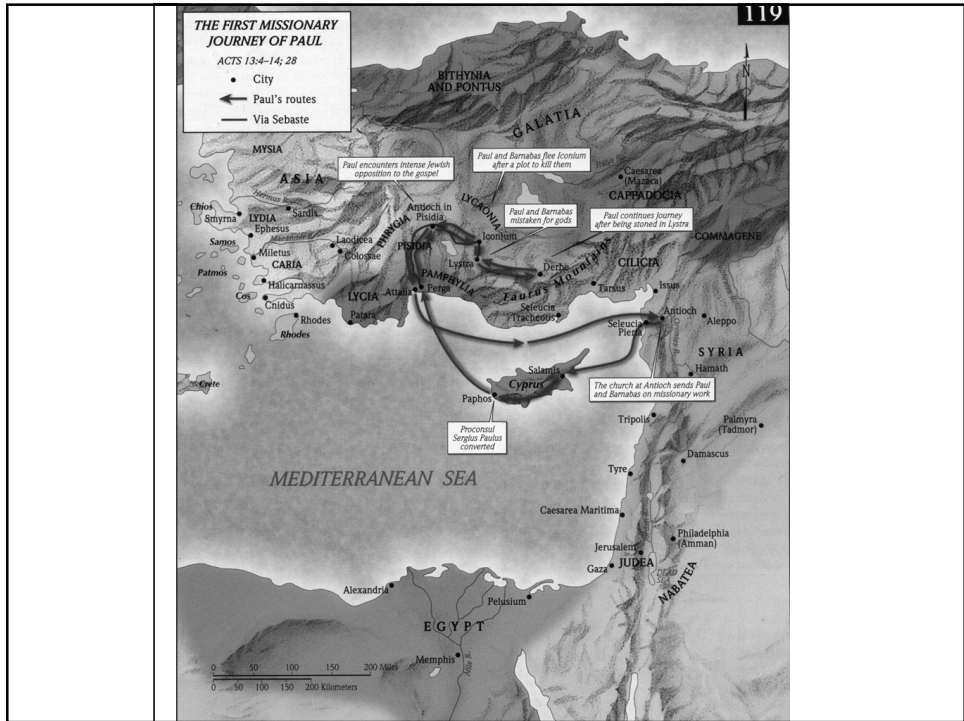
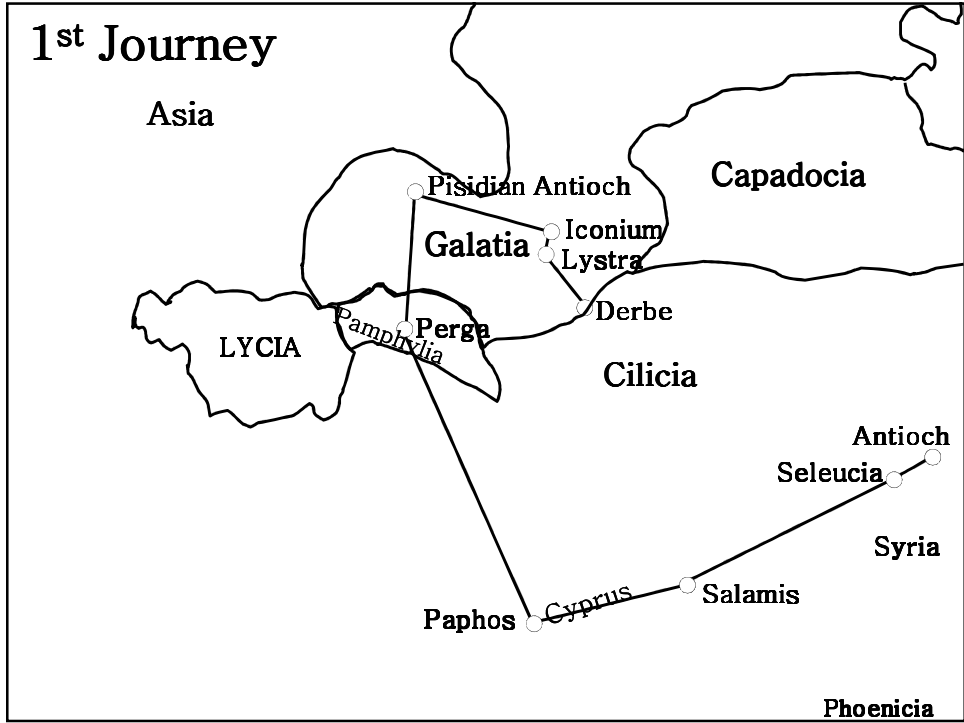

## Seleucia

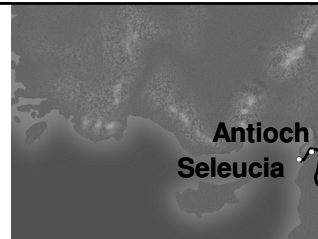

[Acts 13:24]

Pendant qu'ils servaient le Seigneur dans leur ministère et qu'ils jeûnaient, le Saint-Esprit dit: Mettez-moi à part Barnabas et Saul pour l'oeuvre à laquelle je les ai appelés.

Alors, après avoir jeûné et prié, ils leur imposèrent les mains, et les laissèrent partir.

Barnabas et Saul, envoyés par le Saint-Esprit, descendirent à Séleucie, et de là ils s'embarquèrent pour l'île de Chypre.

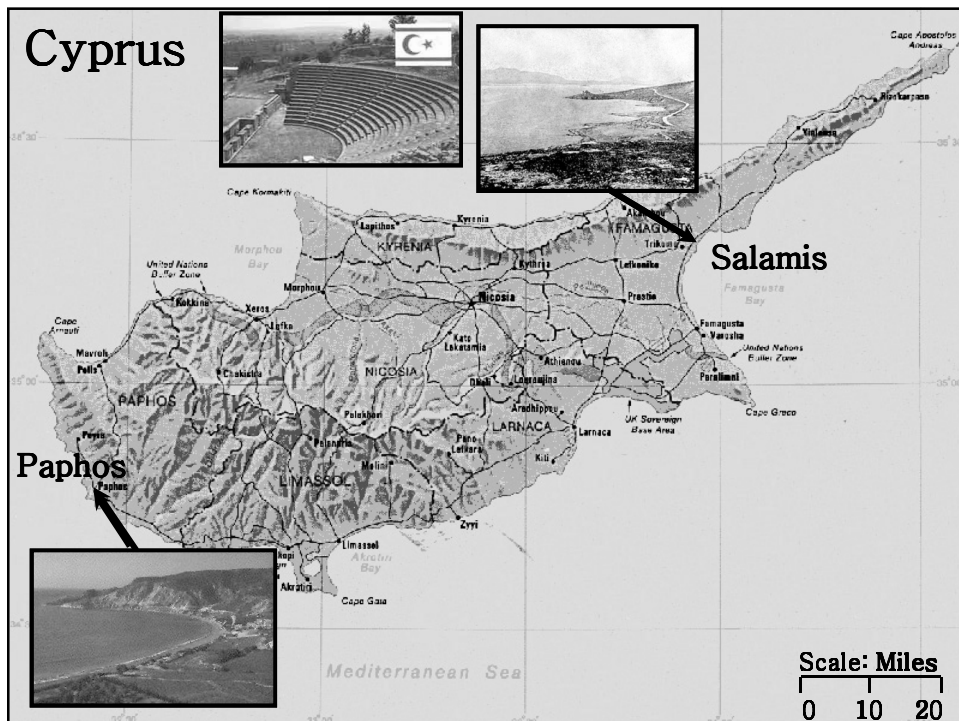

## Lystra

[Acts 14:12]

Ils appelaient Barnabas Jupiter, et Paul Mercure, parce que c'était lui qui portait la parole.

[Acts 14:13]

Le prêtre de Jupiter, dont le temple était à l'entrée de la ville, amena des taureaux avec des bandelettes vers les portes, et voulait, de même que la foule, offrir un sacrifice.

## Lystra

[Acts 14:19]

Alors survinrent d'Antioche et d'Icone des Juifs qui gagnèrent la foule, et qui, après avoir lapidé Paul, le traînèrent hors de la ville, pensant qu'il était mort.

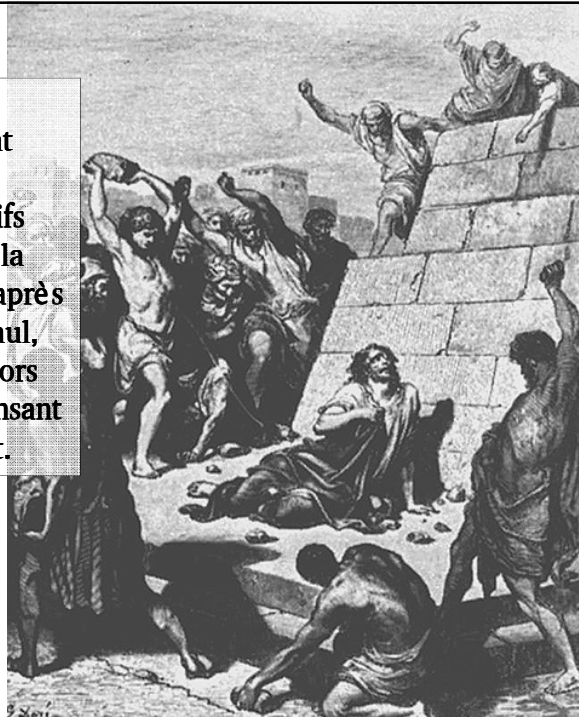

## First Journey

[Acts 14:20-21]

Mais, les disciples l'ayant entouré, il se leva, et entra dans la ville. Le lendemain, il partit pour Derbe avec Barnabas. Quand ils eurent évangélisé cette ville et fait un certain nombre de disciples, ils retournèrent à Lystre, à Icone et à Antioche,

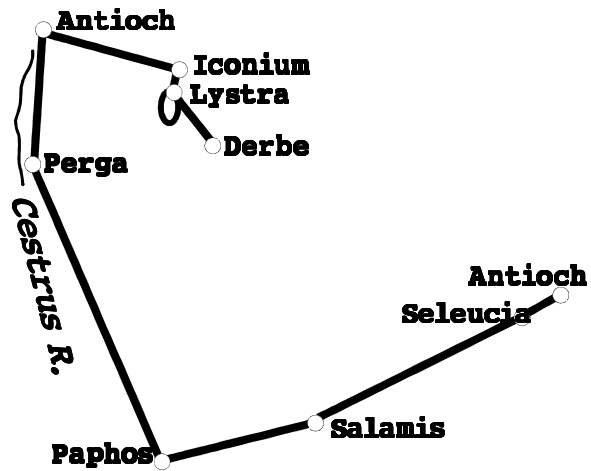

## First Journey

[Acts 14:21-23]

Quand ils eurent évangélisé cette ville et fait un certain nombre de disciples, ils retournèrent à Lystre, à Icone et à Antioche, et l'esprit des disciples, les exhortant à persévérer dans la foi, et disant que c'est par beaucoup de tribulations qu'il nous faut entrer dans le royaume de Dieu. Ils firent nommer des anciens dans chaque Eglise, et, après avoir prié et jeûné, ils les recommandèrent au Seigneur, en qui ils avaient cru.

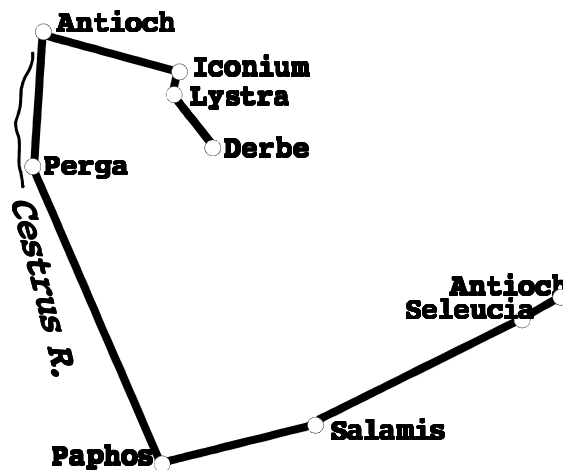

## First Journey

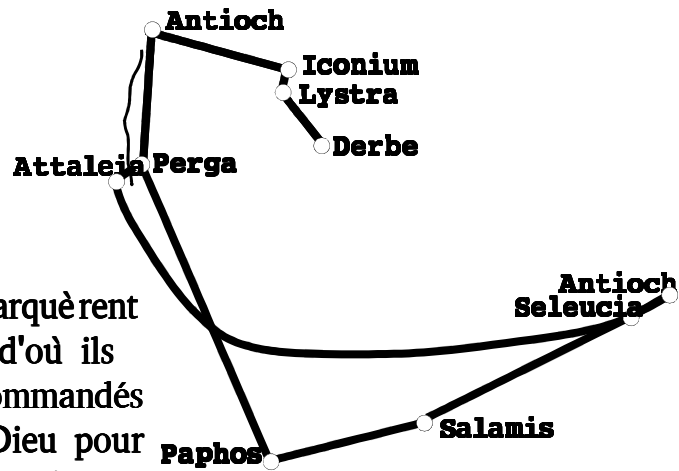

[Acts 14:26]

De là ils s'embarquèrent pour Antioche, d'où ils avaient été recommandés à la grâce de Dieu pour l'oeuvre qu'ils venaient d'accomplir.



[Acts 14:28]

Et ils demeurèrent assez longtemps avec les disciples.

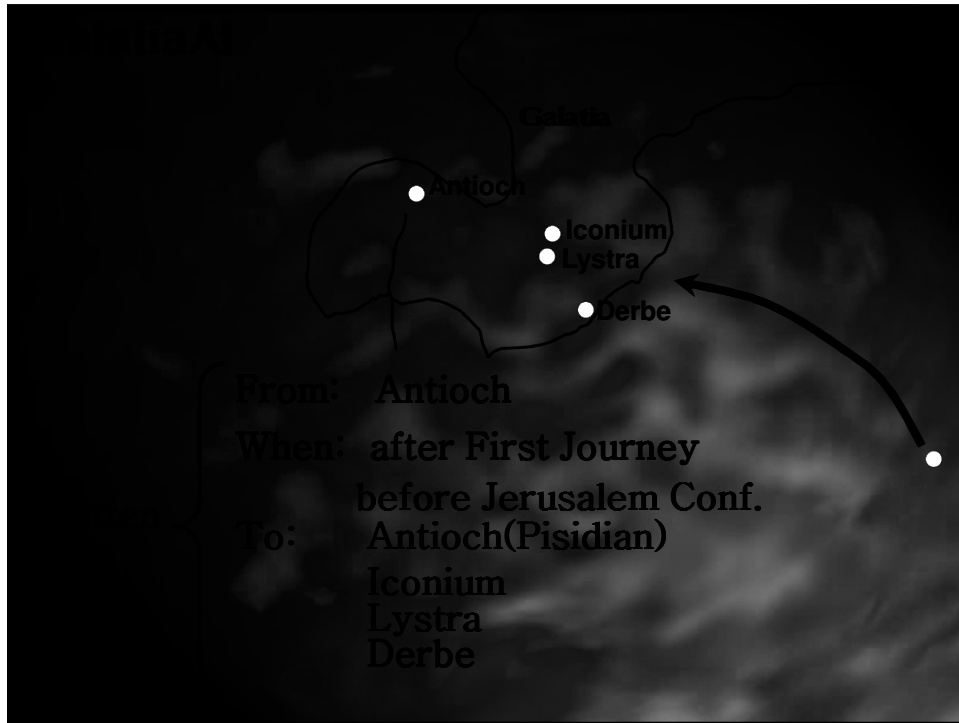

## Pisidian Antioch, Galatia

### Purpose of Writing

To exhort believers to a proper life of faith by exposing the error of legalism and explaining the principles of salvation by faith……

### Circumcision Problem

To defend his apostleship

[Gal 3:1]

O Galates, dépourvus de sens! qui vous a fascinés, vous, aux yeux de qui Jésus-Christ a été peint comme crucifié?(Reason for Jerusalem Conference)

**Cardo Maximus**

1



## Pisidian Antioch, Galatia

[Gal 5:1]

C'est pour la liberté que Christ nous a affranchis. Demeurez donc fermes, et ne vous laissez pas mettre de nouveau sous le joug de la servitude.

Temple of Augustus ~50 A.D.

1

## Jerusalem Conference

### **Paul & Barnaba**

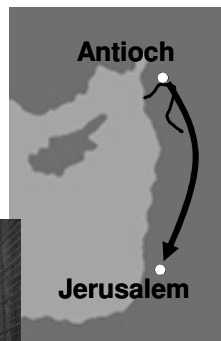

## Jerusalem Conference

Send to Antioch  
Paul & Barnaba  
Judah & Sila

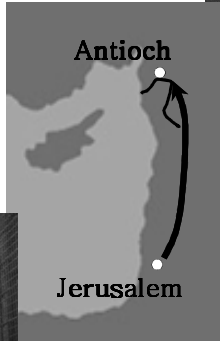

[Acts 15:28-29]  
Car il a paru bon au Saint-Esprit et à nous de ne vous imposer d'autre charge que ce qui est nécessaire, savoir, de vous abstenir des viandes sacrifiées aux idoles, du sang, des animaux étouffés, et de l'impudicité, choses contre lesquelles vous vous trouverez bien de vous tenir en garde. Adieu.

## Paul's 2<sup>nd</sup> Missionary Journey

### Lecture 16

©The Bible Institute of Holy Land

## Paul의 Second Journey(Acts 15:39-18:22)

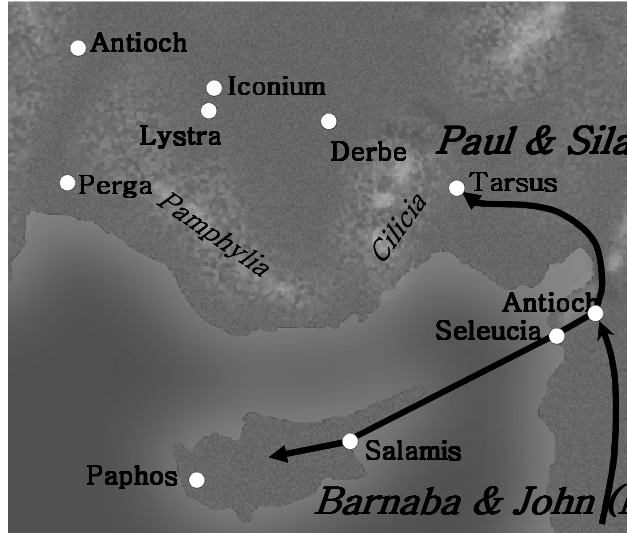

Quelques jours s'écoulèrent, après lesquels Paul dit à Barnabas: Retournons visiter les frères dans toutes les villes où nous avons annoncé la parole du Seigneur, pour voir en quel état ils sont. Barnabas voulait emmener aussi Jean, surnommé Marc; mais Paul jugea plus convenable de ne pas prendre avec eux celui qui les avait quittés depuis la Pamphylie, et qui ne les avait point accompagnés dans leur oeuvre. Ce dissentiment fut assez vif pour être cause qu'ils se séparèrent l'un de l'autre. Et Barnabas, prenant Marc avec lui, s'embarqua pour l'île de Chypre.)

## Second Journey

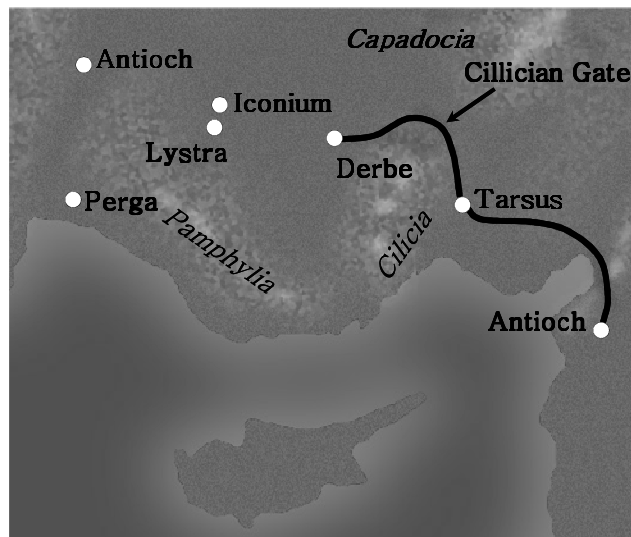

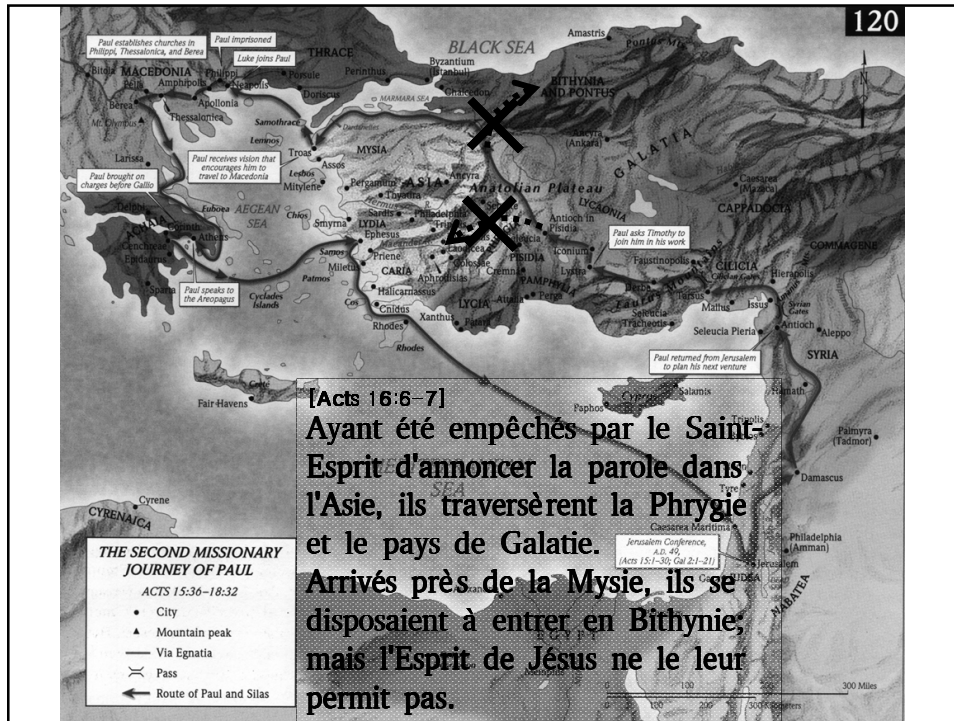

## Philippi

### Rostrum iron rail

Acts 16:22-23

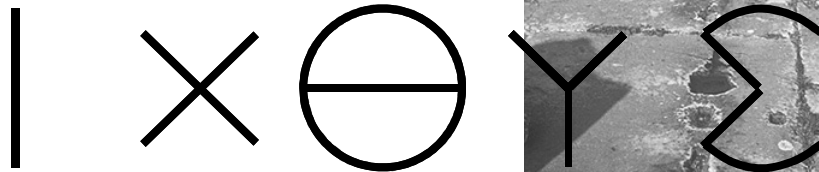

Ιησους Χριστος Θεου  
 Jesus Christ Of God

Υιος Σωτηρ  
 Son Savior

## Thessalonica

### Theater in forum

Acts 17:3-7

expliquant et établissant que le Christ devait souffrir et ressusciter des morts. Et Jésus que je vous annonce, disait-il, c'est lui qui est le Christ.

Quelques-uns d'entre eux furent persuadés, et se joignirent à Paul et à Silas, ainsi qu'une grande multitude de Grecs craignant Dieu, et beaucoup de femmes de qualité.

## Thessalonica

### Theater reconstruction

Mais les Juifs, jaloux prirent avec eux quelques méchants hommes de la populace, provoquèrent des attroupements, et répandirent l'agitation dans la ville. Ils se portèrent à la maison de Jason, et ils cherchèrent Paul et Silas, pour les amener vers le peuple.

Ne les ayant pas trouvés, ils traînèrent Jason et quelques frères devant les magistrats de la ville, en criant: Ces gens, qui ont bouleversé le monde, sont aussi venus ici, et Jason les a reçus. Ils agissent tous contre les édits de César, disant qu'il y a un autre roi, Jésus.

**Thessalonica**  
**Arches under forum**



**Thessalonica**  
**Theater**  
**reconstruction**

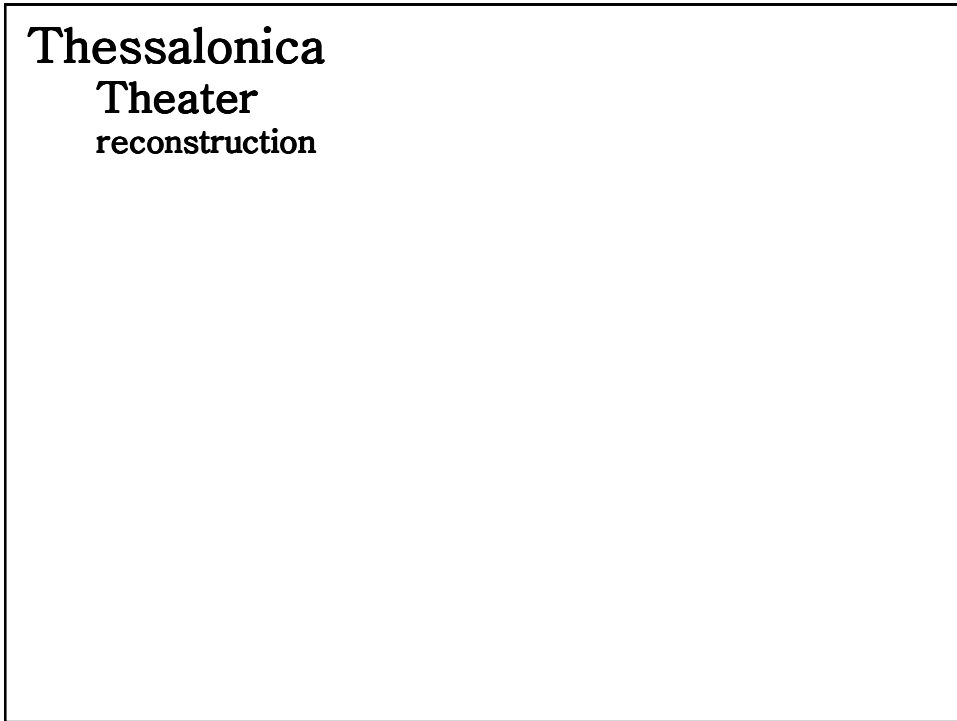

**Thessalonica  
Theater  
reconstruction**



*Dedicated to*  
***The Nameless God***  
*by*  
***Maktas son of Vahrallay***

Car, en parcourant votre ville et en considérant les objets de votre dévotion, j'ai même découvert un autel avec cette inscription: A un dieu inconnu! Ce que vous révèrez sans le connaître, c'est ce que je vous annonce. [Acts 17:23]

Corinth agora  
Synagogue lintel  
Acts 18:4

ΓΩΓΗ ΕΒΡ  
συναγωγή εβραίοι  
*Synagogue of the Hebrews*



**Eraetus pavement – set before 50 A.D.  
Rom 16:23, Acts 19:22, 2 Tim 4:20**

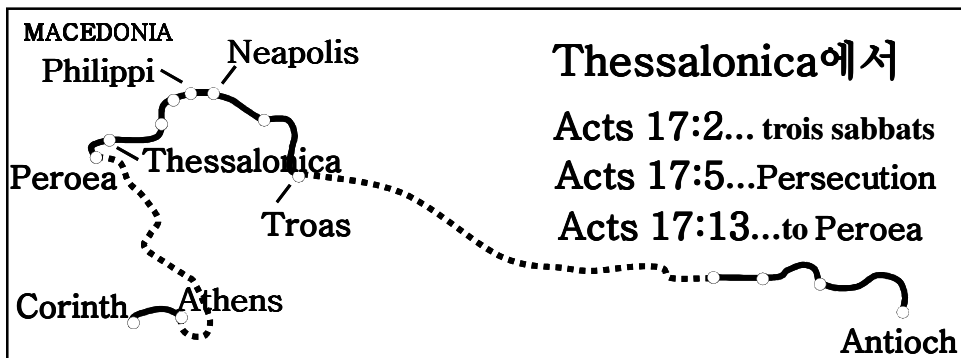

**1 Thessalonica**

Written { From: Corinth  
 When: during 2 journey  
 To: Thessalonica

**Second  
 Journey**

## Paul wrote to Thessalonika

### Purpose of Writing:

To commend steadfastness of faith under testing and to instruct concerning the Lord's coming and the believer's responsibility in light of it.

- 1 Thess 2:14...
- 1 Thess 4:1-3...
- 1 Thess 4:13-18...

1

## Paul wrote to Thessalonika

### 2 Thessalonians

Written {  
From: Corinth  
When: during 2 journey  
To: Thessalonica

1

**Purpose of Writing:** To commend believers for their growing faith and extort them to industrious living by clarifying issues of the day of the Lord.

2 Thess 1:4  
2 Thess 2:2

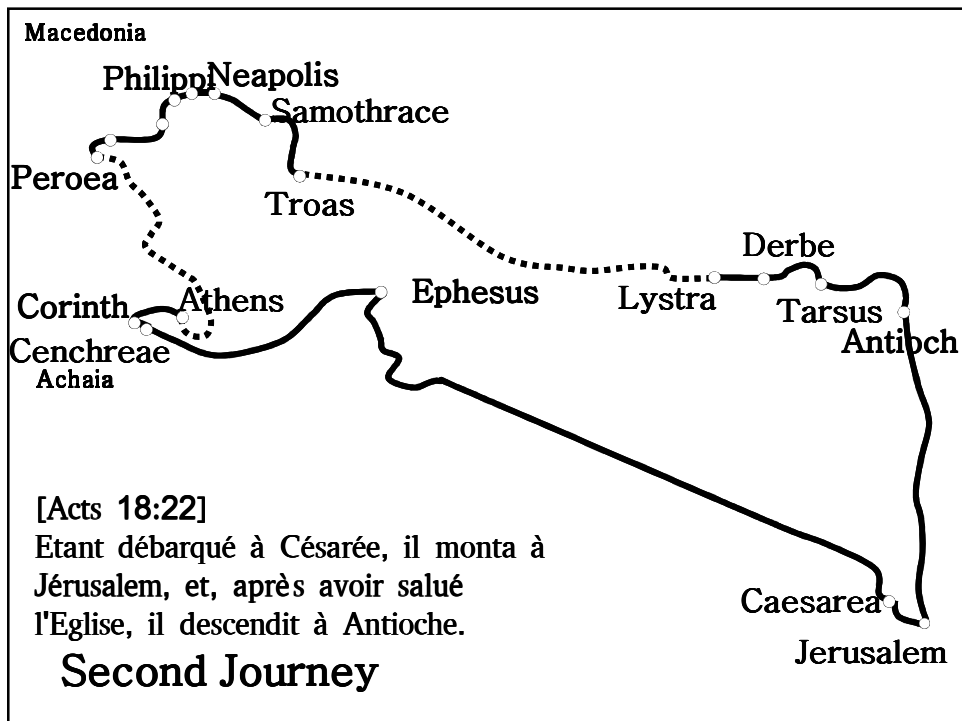

# 3<sup>rd</sup> Missionary Journey

## Lecture 17

©The Bible Institute of Holy Land

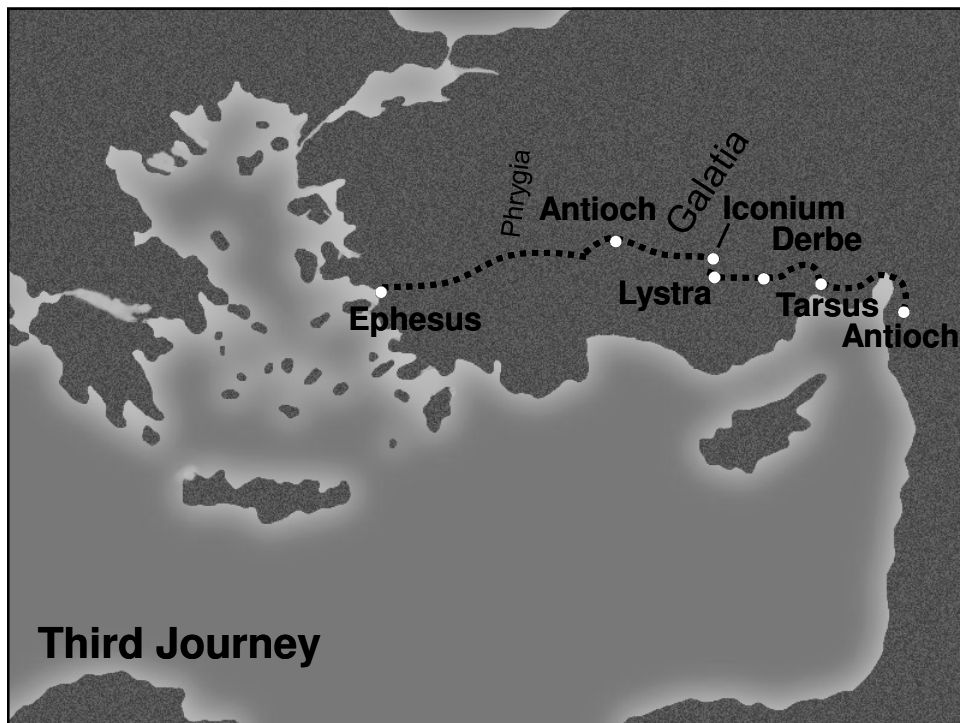

## Ephesus site map

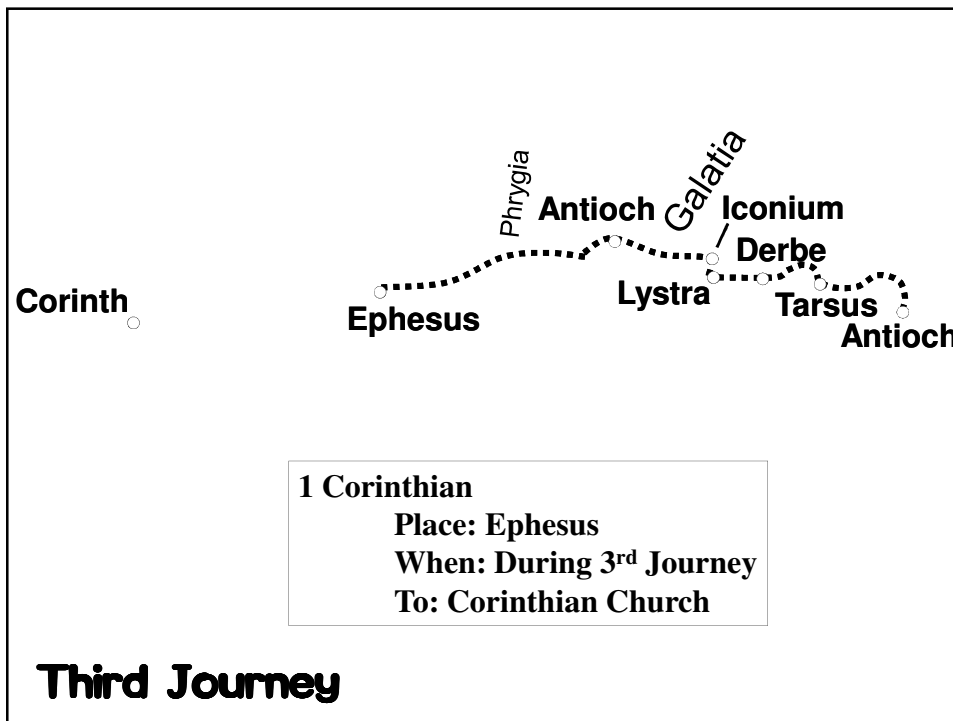
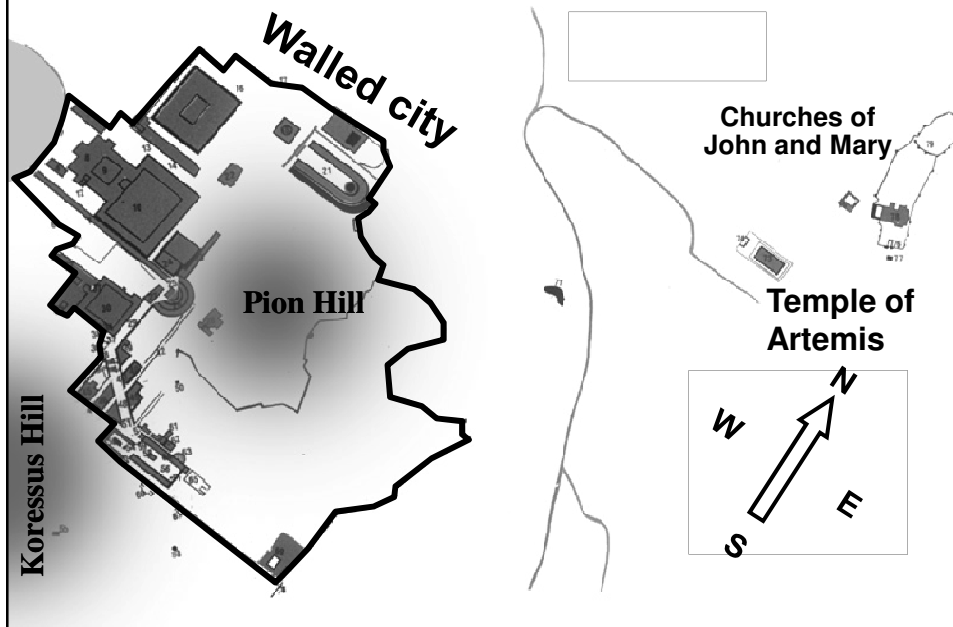

## Isthmia, near Corinth

[1 Cor 9:24-27]

Ne savez-vous pas que ceux qui courent dans le stade courent tous, mais qu'un seul remporte le prix? Courez de manière à le remporter. Tous ceux qui combattent s'imposent toute espèce d'abstinences, et ils le font pour obtenir une couronne corrompible; mais nous, faisons-le pour une couronne incorruptible.

Moi donc, je cours, non pas comme à l'aventure; je frappe, non pas comme battant l'air. Mais je traite durement mon corps et je le tiens assujéti, de peur d'être moi-même rejeté, après avoir prêché aux autres.

Starting Gate for Panhellenic games <sup>1</sup>

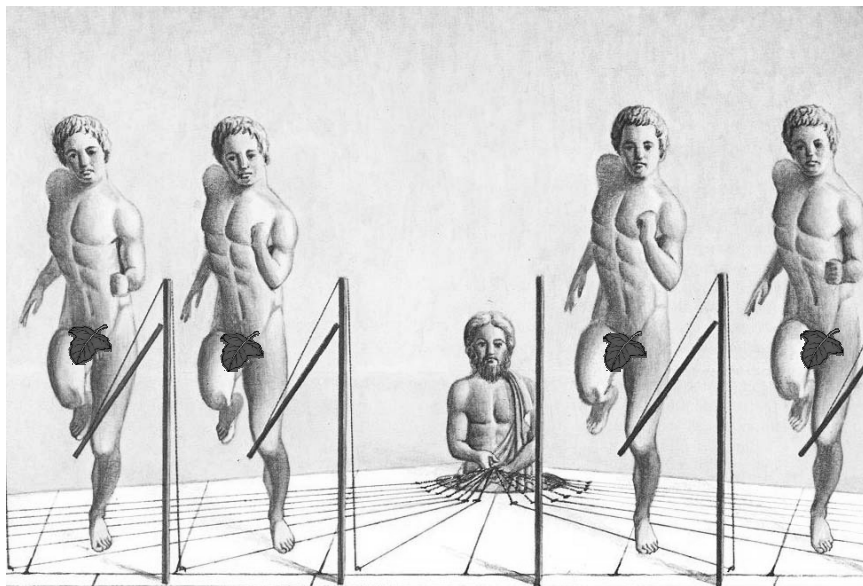

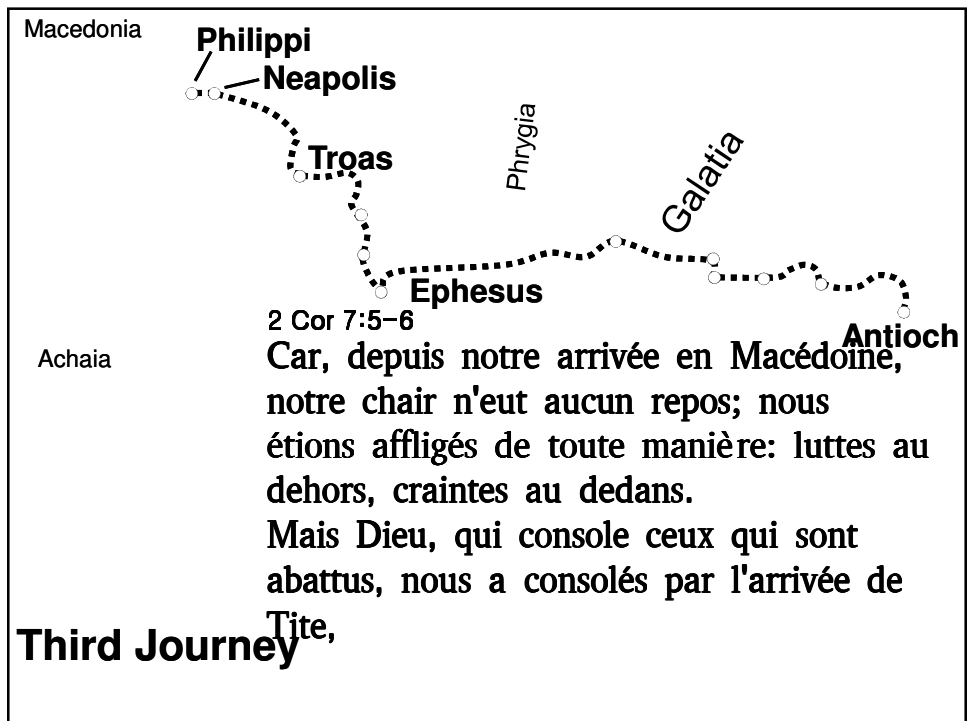
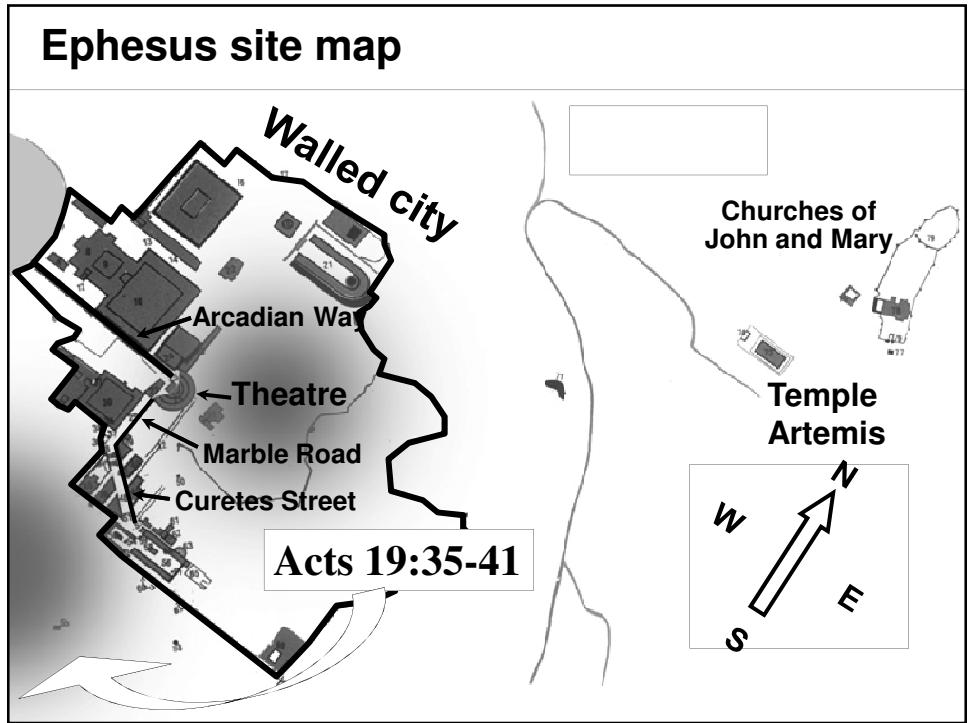

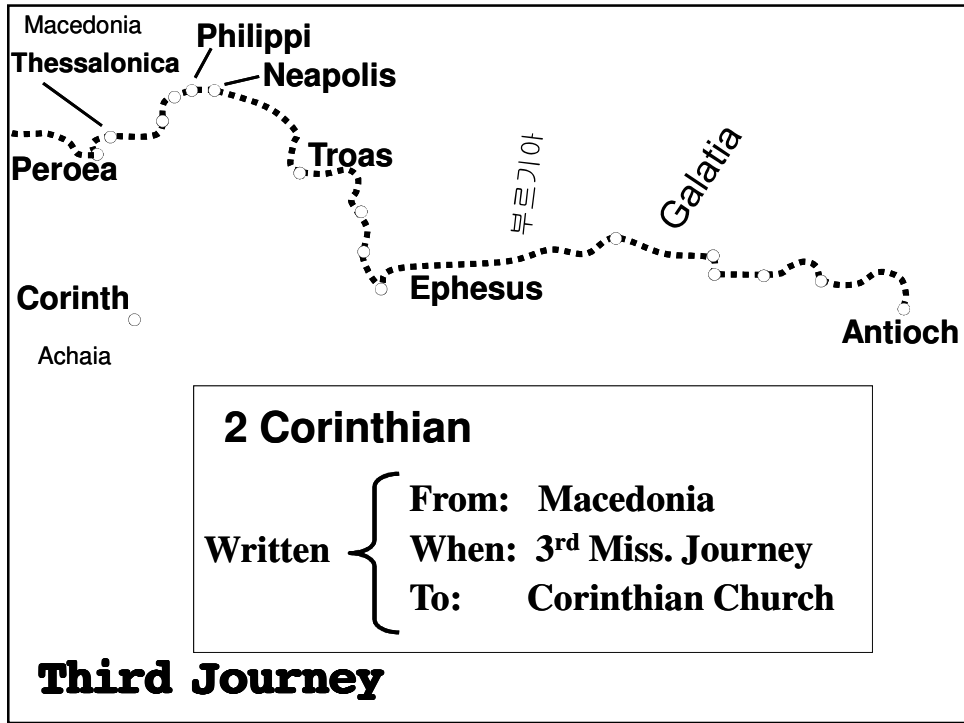

## Corinth

- Peirene Fountain

**고후 4:5...False Teachers**

**고후 9:3-4...offering 1**



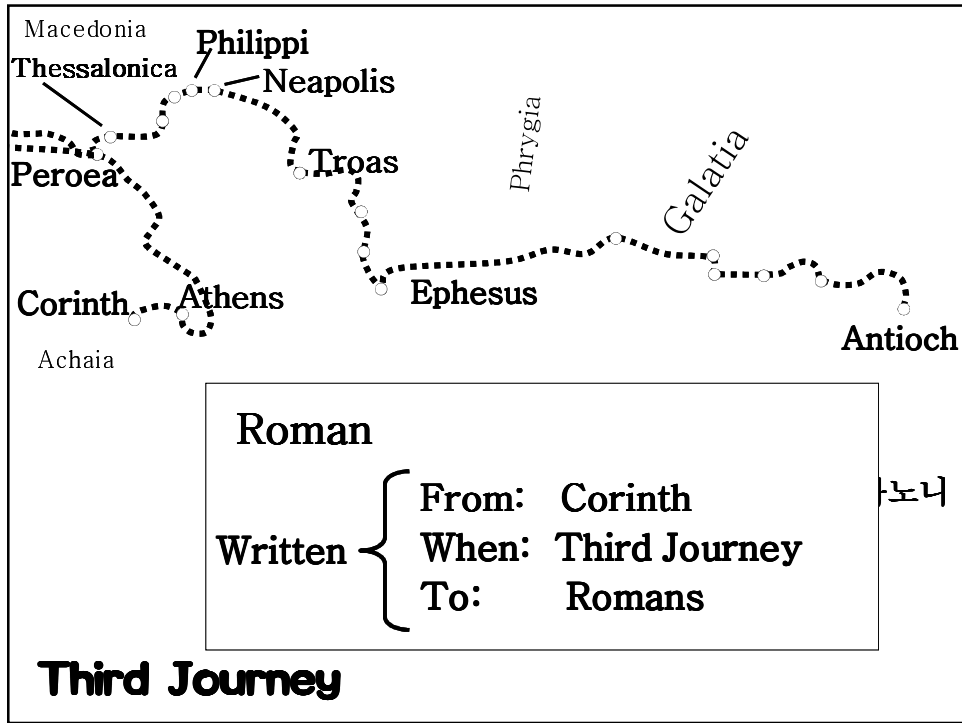

## Corinth

**Purpose of Writing:**  
**To instruct believers in the basic truths of the Gospel of salvation as preparation for a future ministry among and through them.**

Acts 20:2-3  
 Il parcourut cette contrée, en adressant aux disciples de nombreuses exhortations. Puis il se rendit en Grèce, où il séjourna trois mois. Il était sur le point de s'embarquer pour la Syrie, quand les Juifs lui dressèrent des embûches. Alors il se décida à reprendre la route de la Macédoine.

## Visiting Jerusalem & Paul's Old Years

### Lecture 18

©The Bible Institute of Holy Land

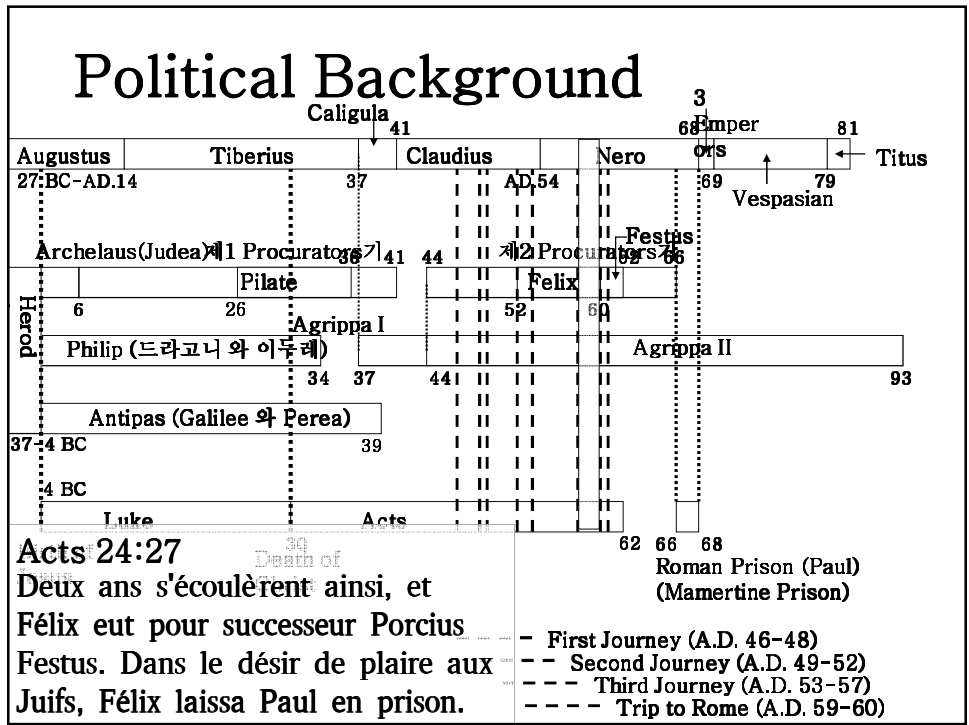
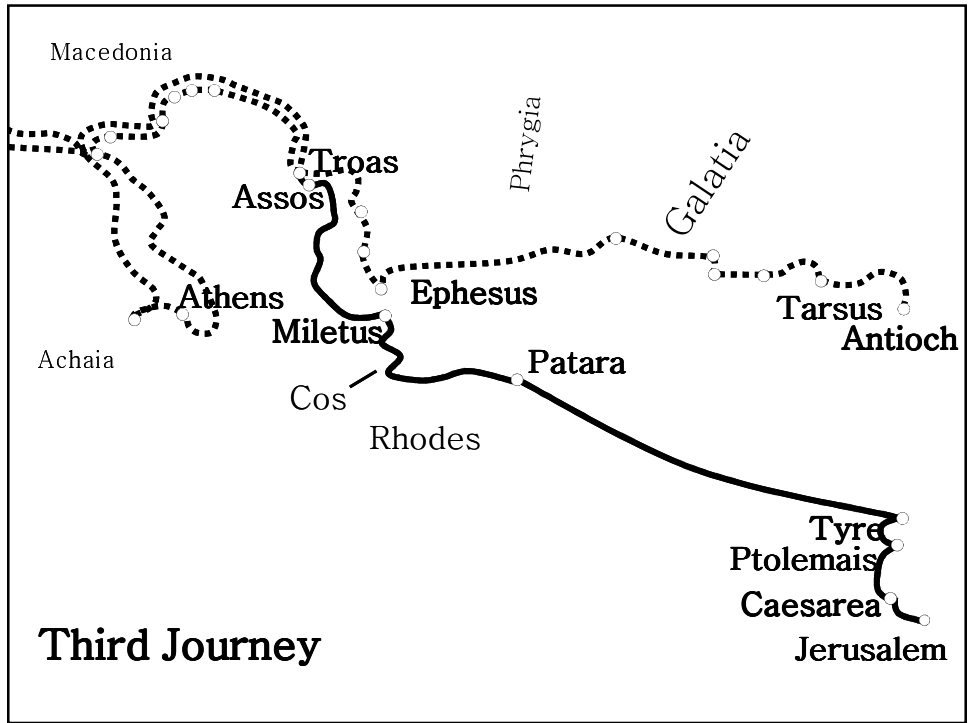

## Phoenix , Crete

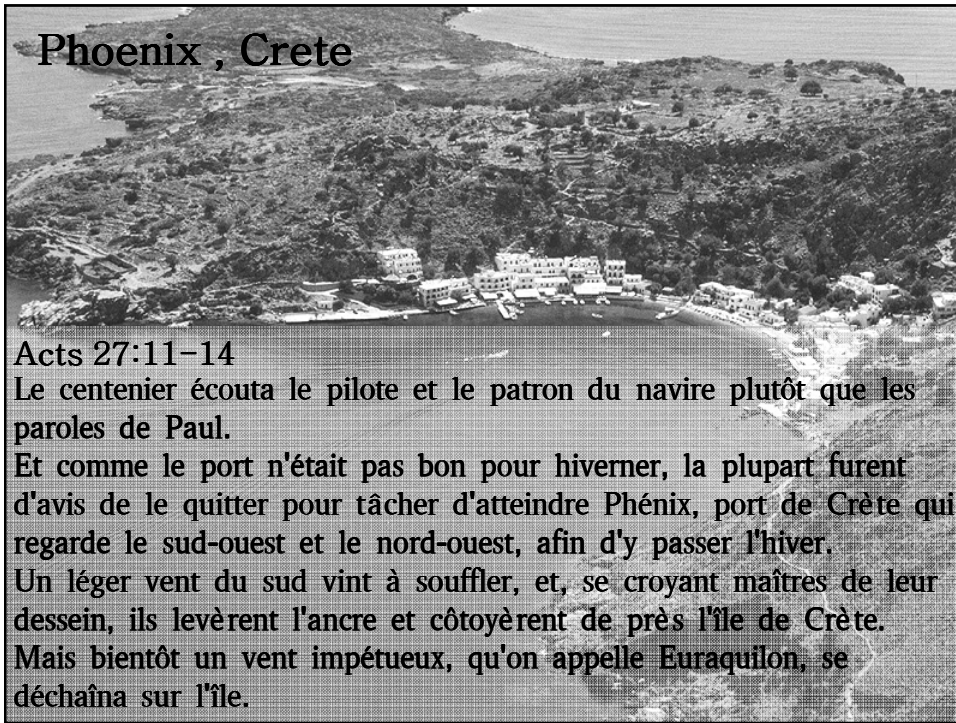

Acts 27:11-14

Le centenier écouta le pilote et le patron du navire plutôt que les paroles de Paul.

Et comme le port n'était pas bon pour hiverner, la plupart furent d'avis de le quitter pour tâcher d'atteindre Phénix, port de Crète qui regarde le sud-ouest et le nord-ouest, afin d'y passer l'hiver.

Un léger vent du sud vint à souffler, et, se croyant maîtres de leur dessein, ils levèrent l'ancre et côtoyèrent de près l'île de Crète.

Mais bientôt un vent impétueux, qu'on appelle Euraquilon, se déchaîna sur l'île.

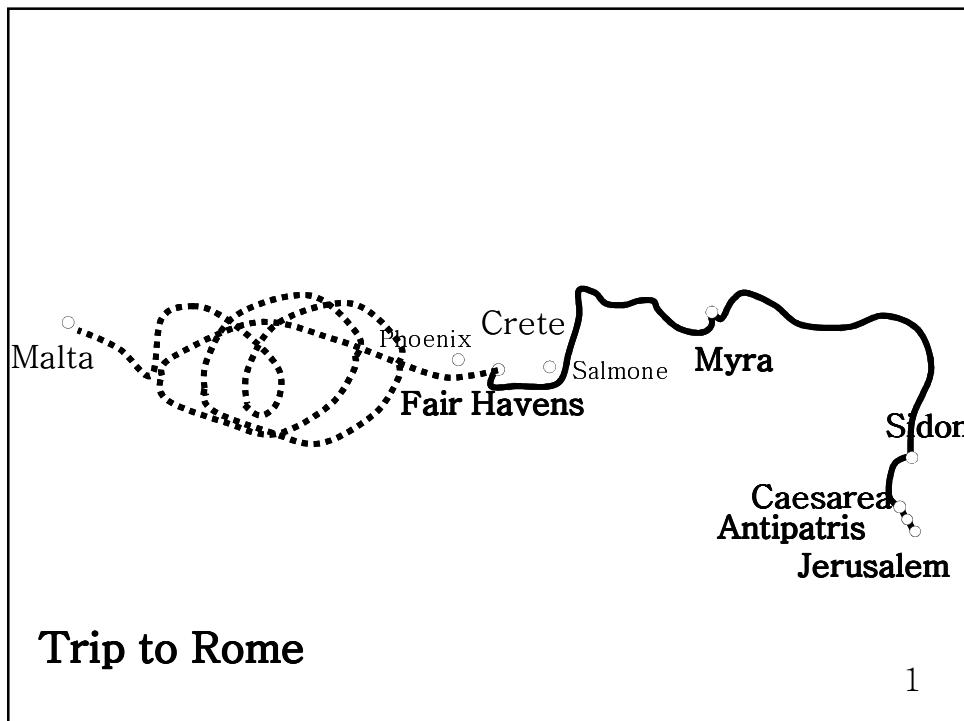

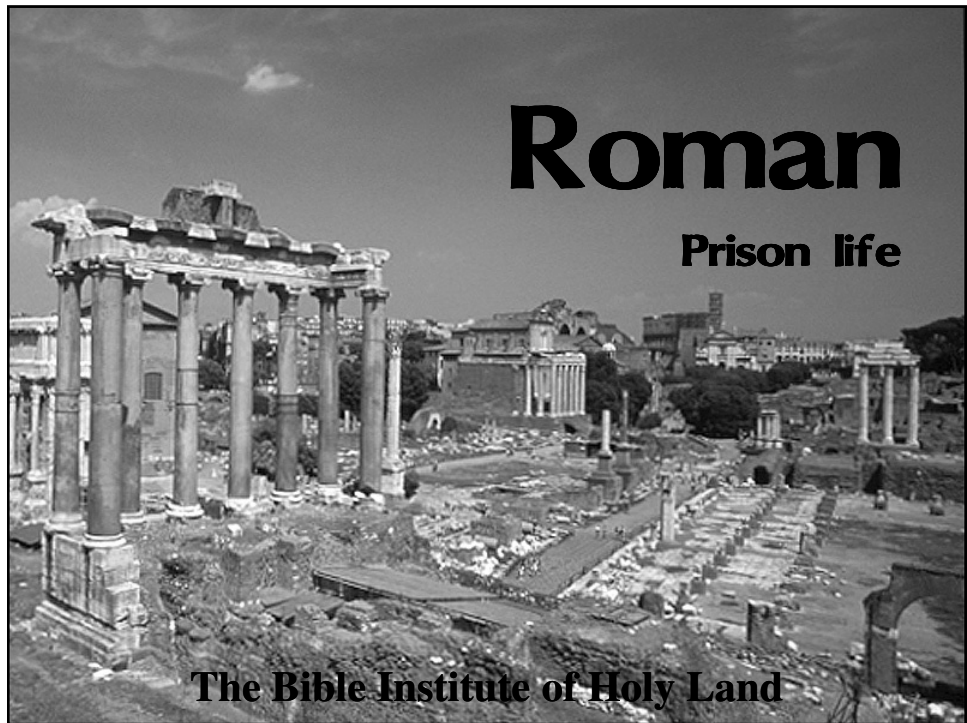
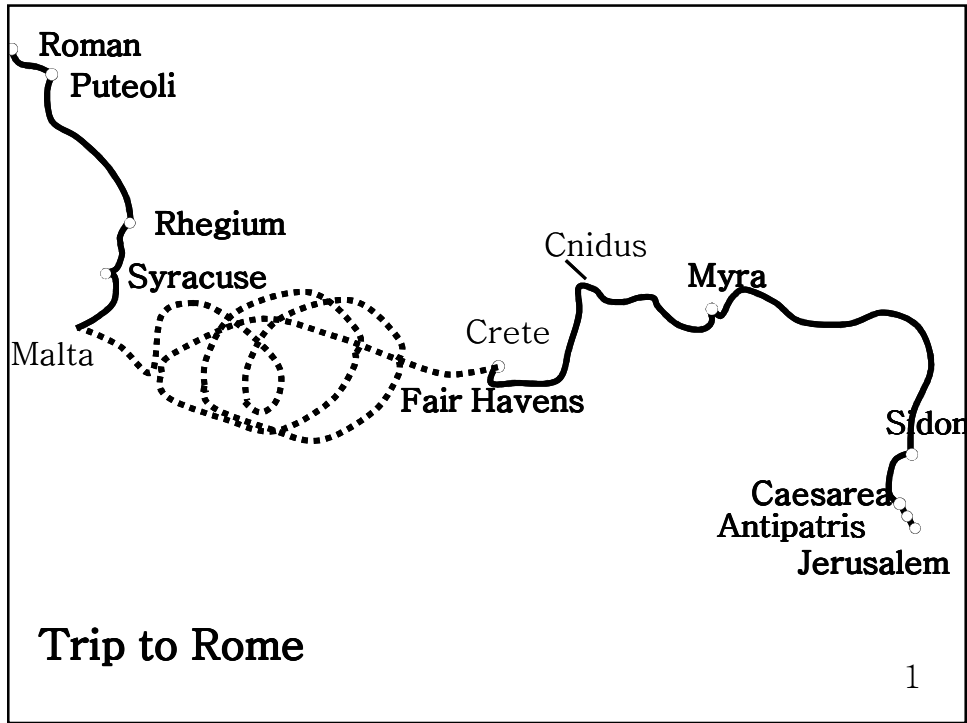

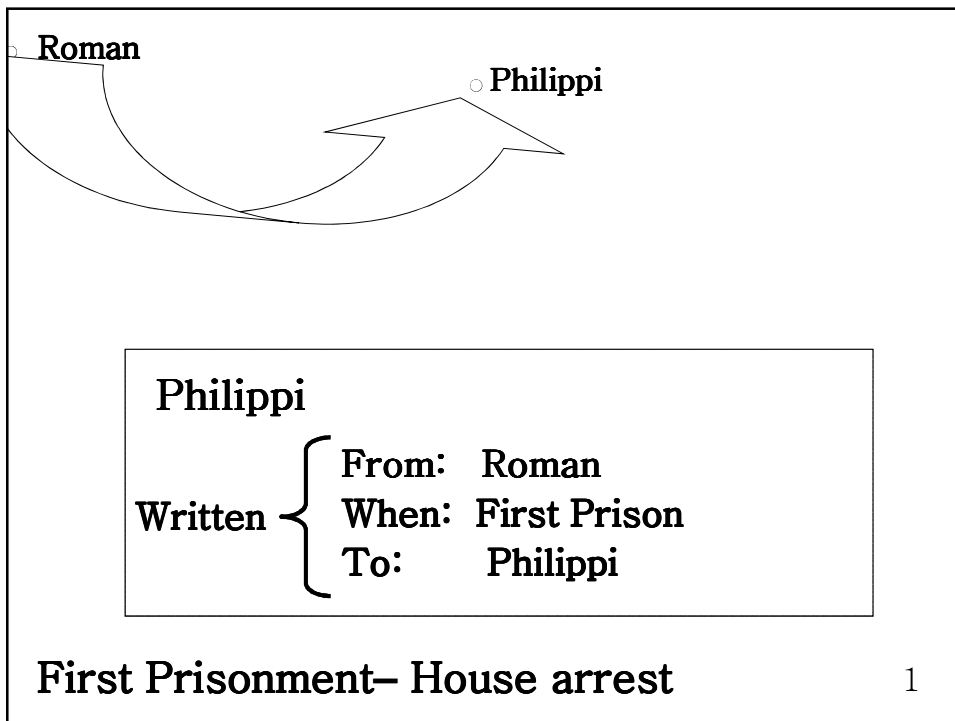
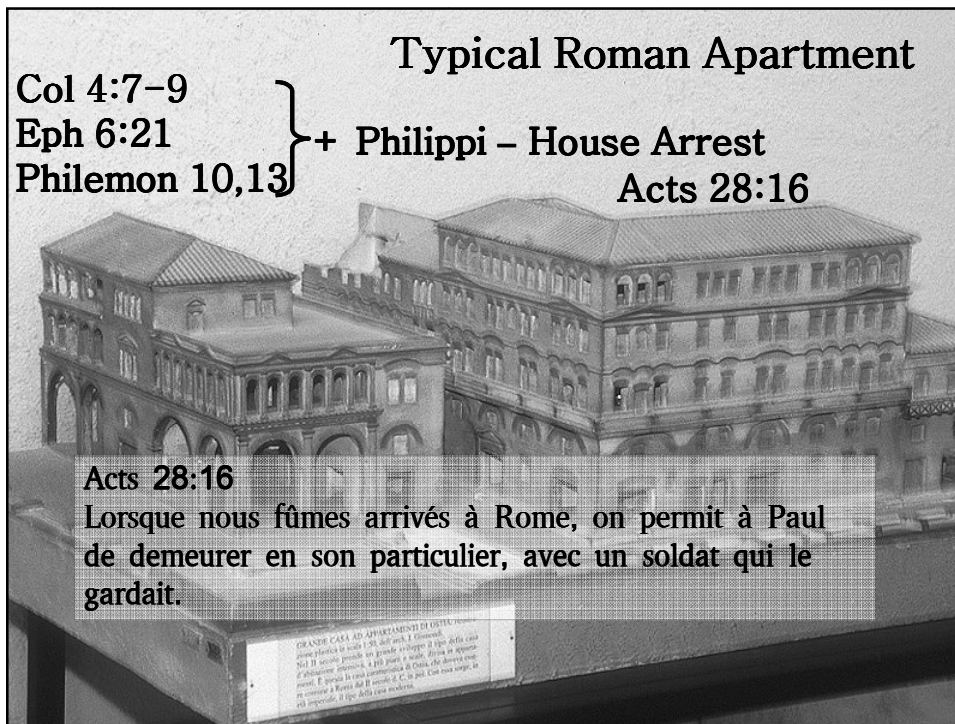

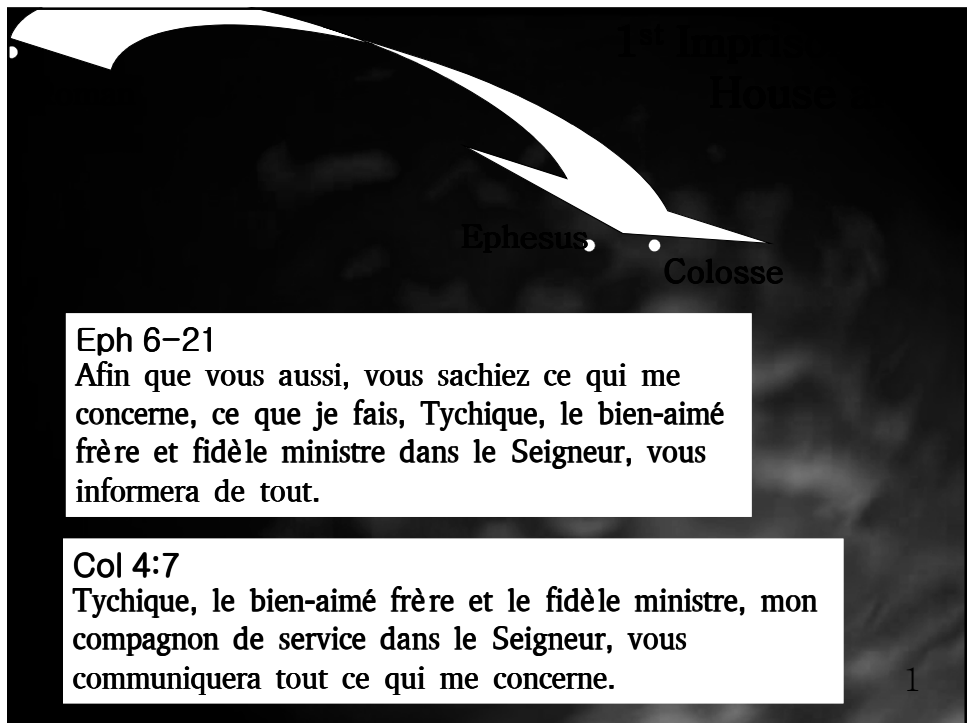
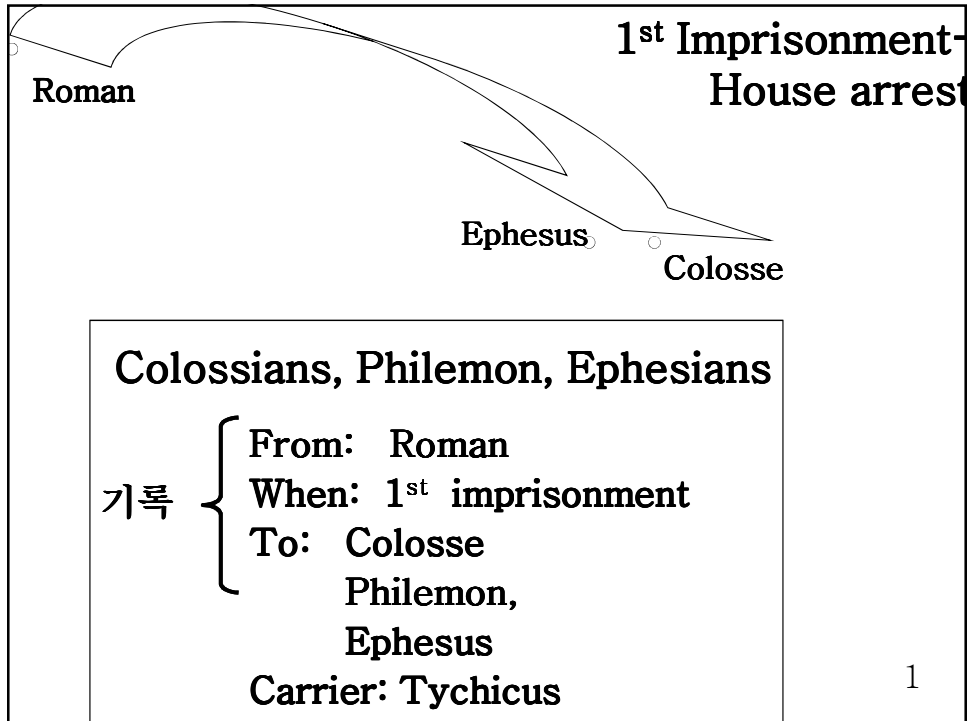

**Purpose of Writing:**

To encourage unity and spiritual maturity in the body of Christ by explaining the heavenly riches and earthly responsibilities of believers

**Purpose of writing(Philemon)**

To act as a mediator between a slave and his master, pleading the merit and position of the intercessor for the guilt of a Christian slave.

**Philemon 1:10**

Je te prie pour mon enfant, que j'ai engendré étant dans les chaînes, Onésime,



# Colosse

## Purpose of Writing(Colossians):

To strengthen and confirm believers in their faith by demonstrating the pre-eminence of Christ over all things and refuting the errors of Gnosticism

## Col 4:12-13

.... Epaphras, qui est des vôtres, vous salue: serviteur de Jésus-Christ, il ne cesse de combattre pour vous dans ses prières, afin que, parfaits et pleinement persuadés, vous persistiez dans une entière soumission à la volonté de Dieu.

Car je lui rends le témoignage qu'il a une grande sollicitude pour vous, pour ceux de Laodicée, et pour ceux d'Hiérapolis.....

1

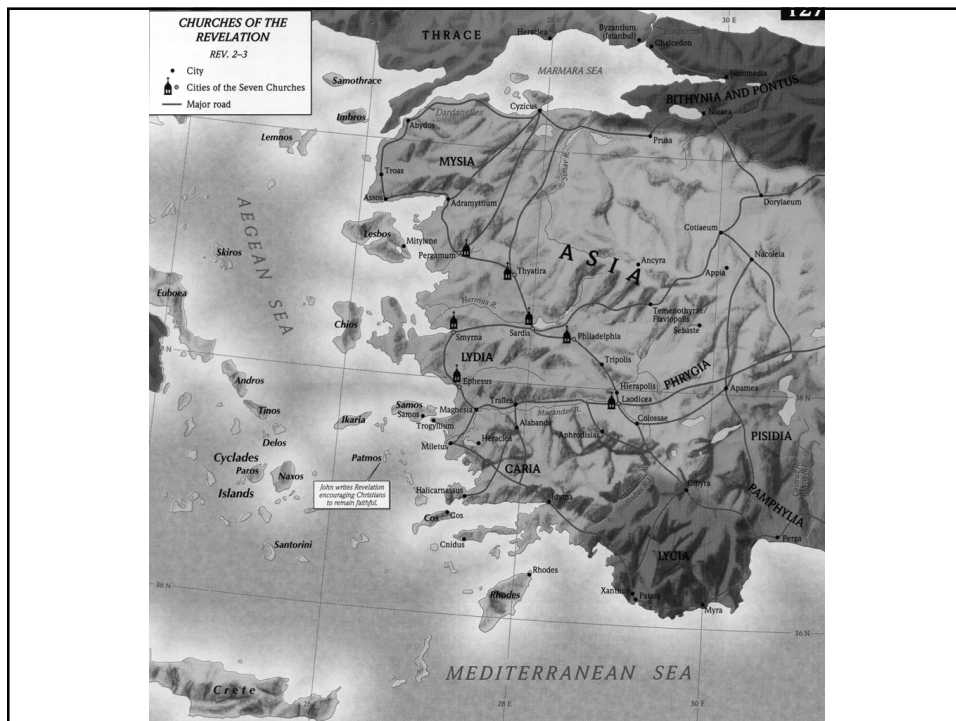

## “Between two Imprisonments”

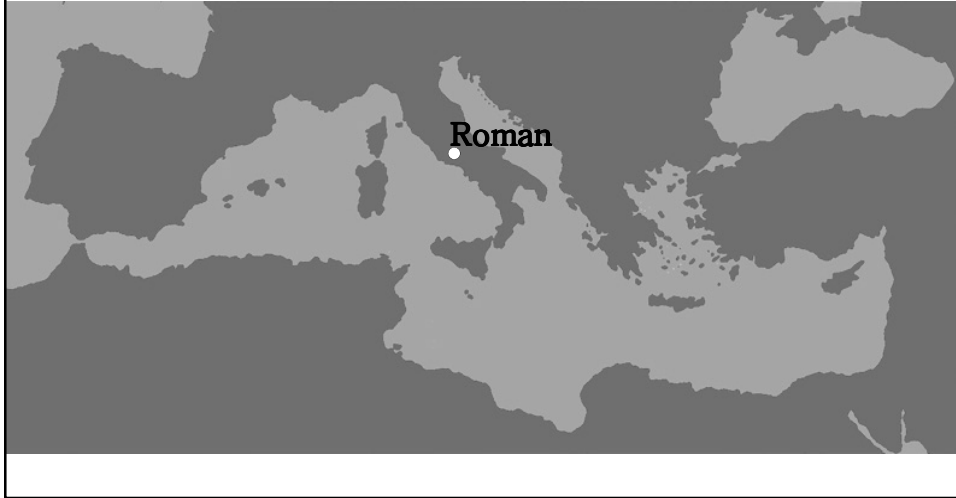

## Political Background

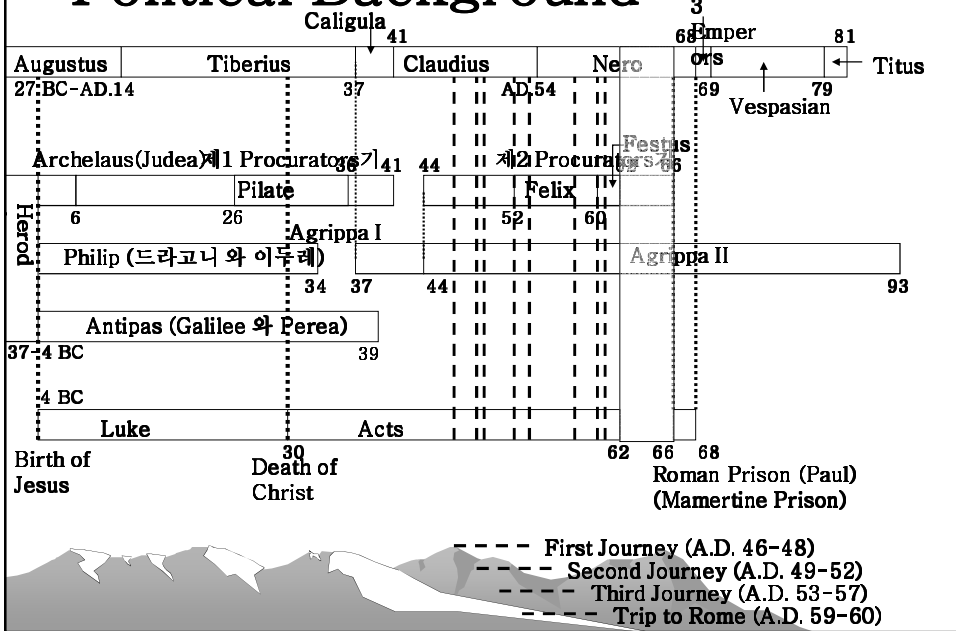

“Between two Imprisonments”



“Between two Imprisonments”

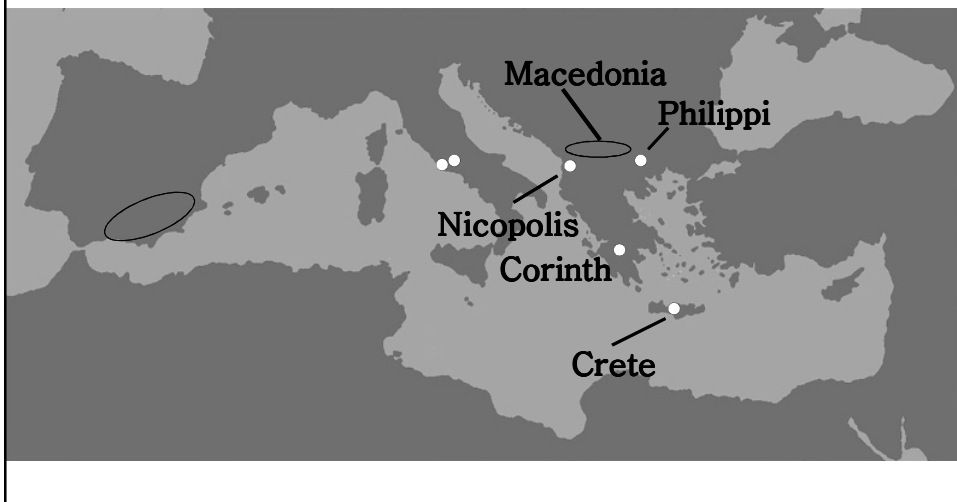

“Between two Imprisonments”

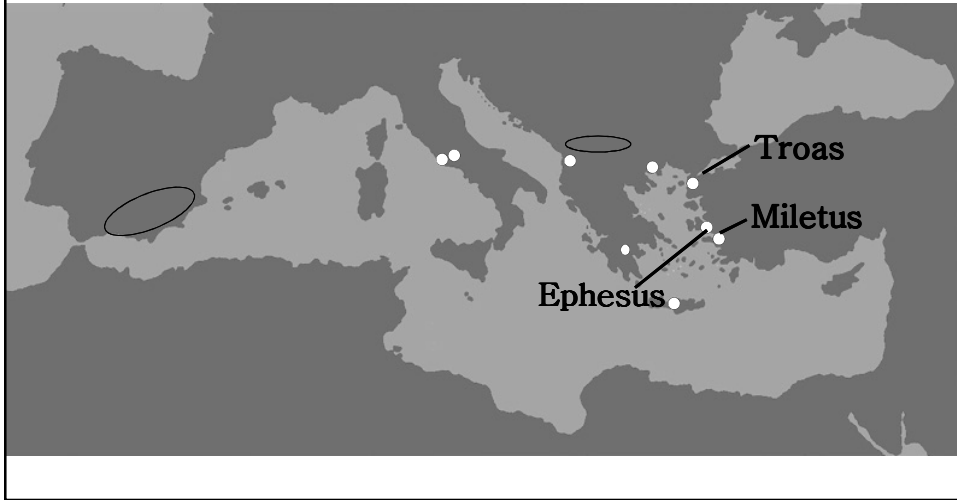

“Between two Imprisonments”

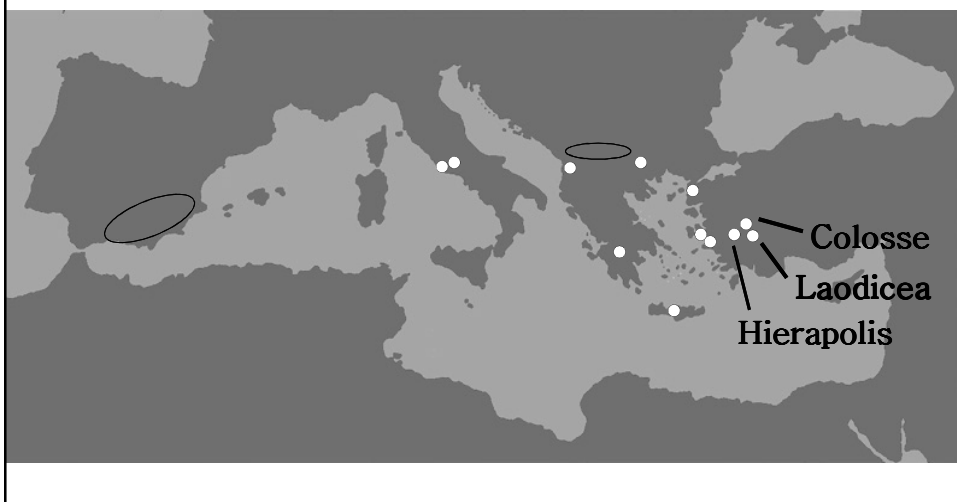

Nicopolis

Crete

**Titus**

Written { From: Nicopolis(Tit 3:12)  
When: B/W Imprisonments  
To: Titus @Crete

**Between the imprisonments**

1

**Crete**

Tit 1:5 ...

Tit 1:9...

**Purpose of Writing(Titus):**

**To direct and authorize Titus concerning the Christian responsibilities of church leaders and other believers to maintain good works and combat error.**

Macedonia

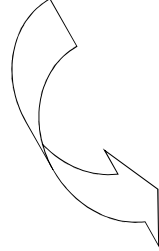

Ephesus

## 1 Timothy

Written { From: Macedonia  
When: between the imprisonments  
To: Timothy (Ephesus)

Between the imprisonments

1

## Ephesus

### **Purpose of Writing(1 Tim):**

**To encourage and guide a pastor and his church by warning against false teaching and give instruct with respect to life in the church**

1 Tim 1:4

et de ne pas s'attacher à des fables et à des généalogies sans fin, qui produisent des discussions plutôt qu'elles n'avancent l'oeuvre de Dieu dans la foi.

1

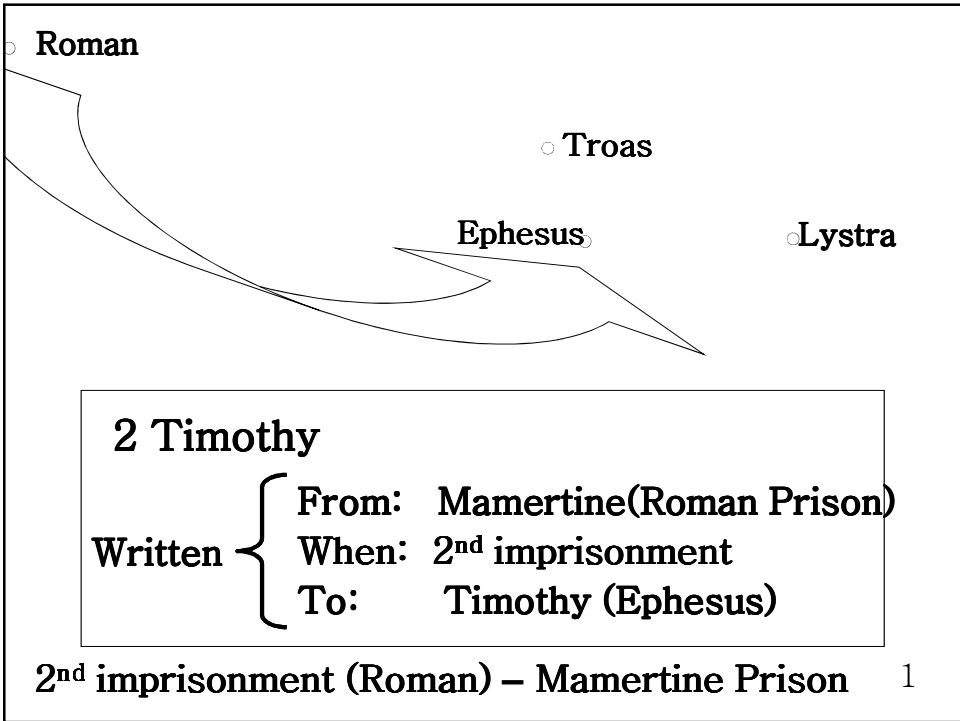
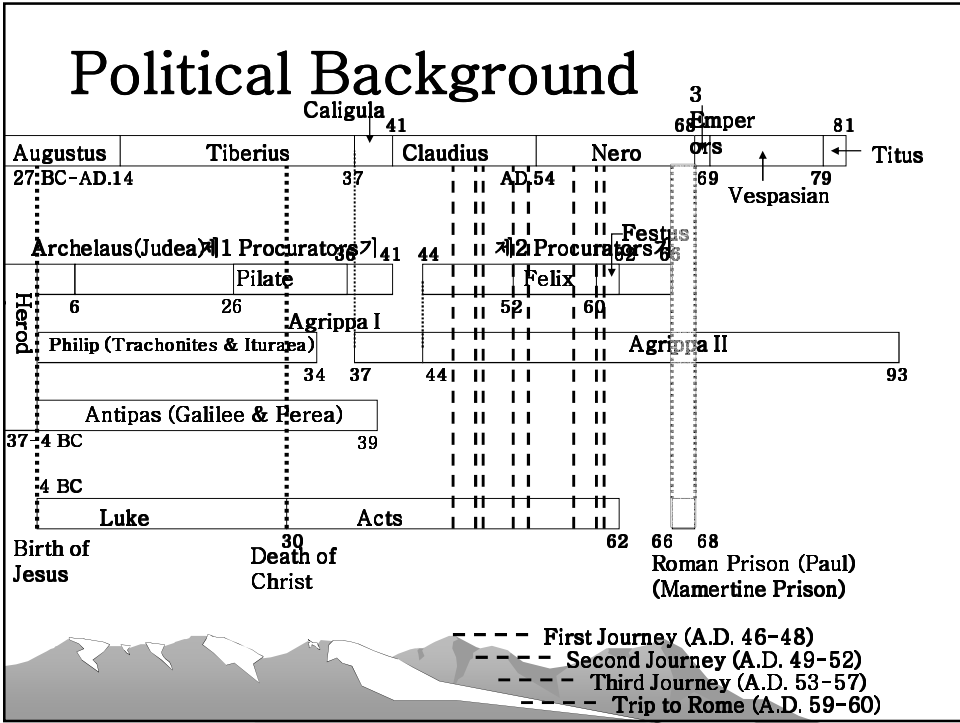

**Purpose of Writing(답후):**

To encourage, strengthen, and guide Timothy in the pastoral ministry.

**2 Tim 4:11-13**

Luc seul est avec moi. Prends Marc, et amène-le avec toi, car il m'est utile pour le ministère.

J'ai envoyé Tychique à Ephèse.

Quand tu viendras, apporte le manteau que j'ai laissé à Troas chez Carpus, et les livres, surtout les parchemins.

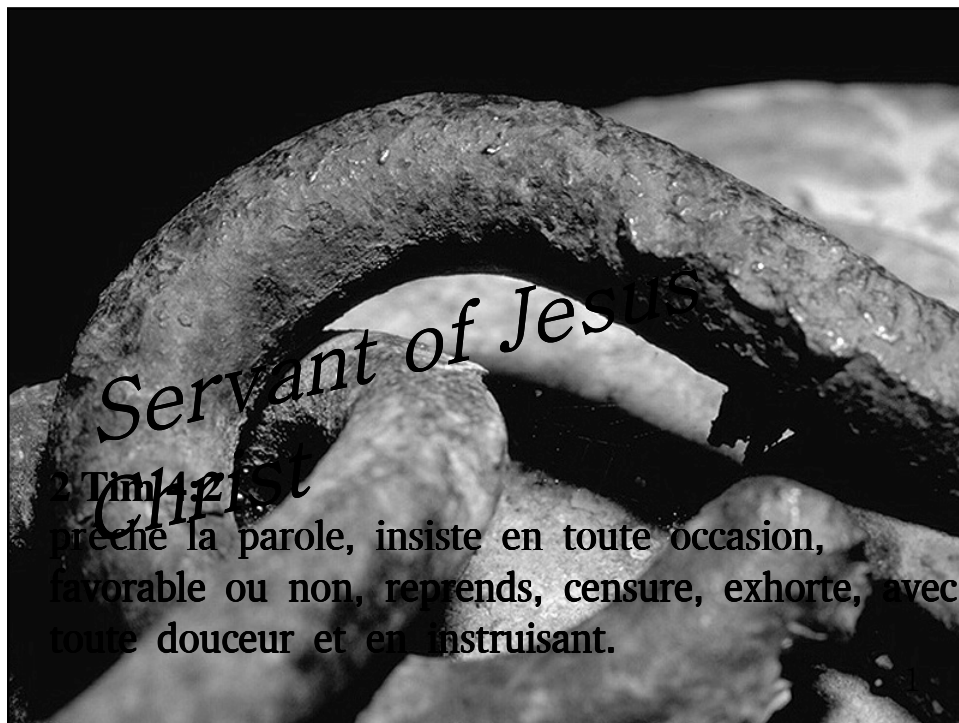



**John 21:18-19**

**En vérité, en vérité, je te le dis, quand tu étais plus jeune, tu te ceignais toi-même, et tu allais où tu voulais; mais quand tu seras vieux, tu étendras tes mains, et un autre te ceindra, et te mènera où tu ne voudras pas.**

**Il dit cela pour indiquer par quelle mort Pierre glorifierait Dieu. Et ayant ainsi parlé, il lui dit: Suis-moi.**

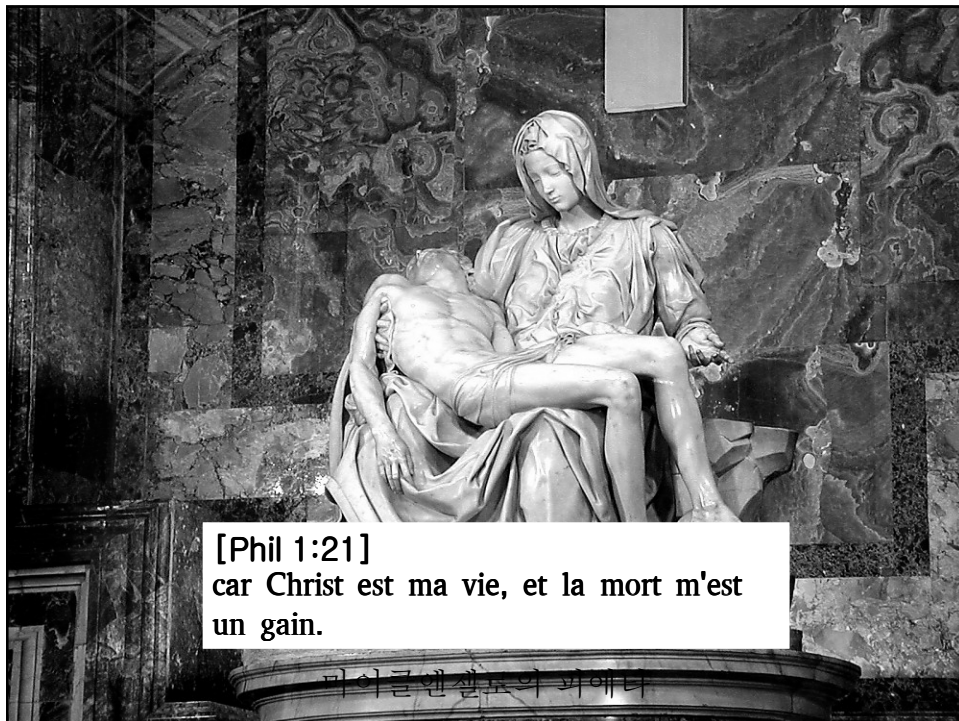

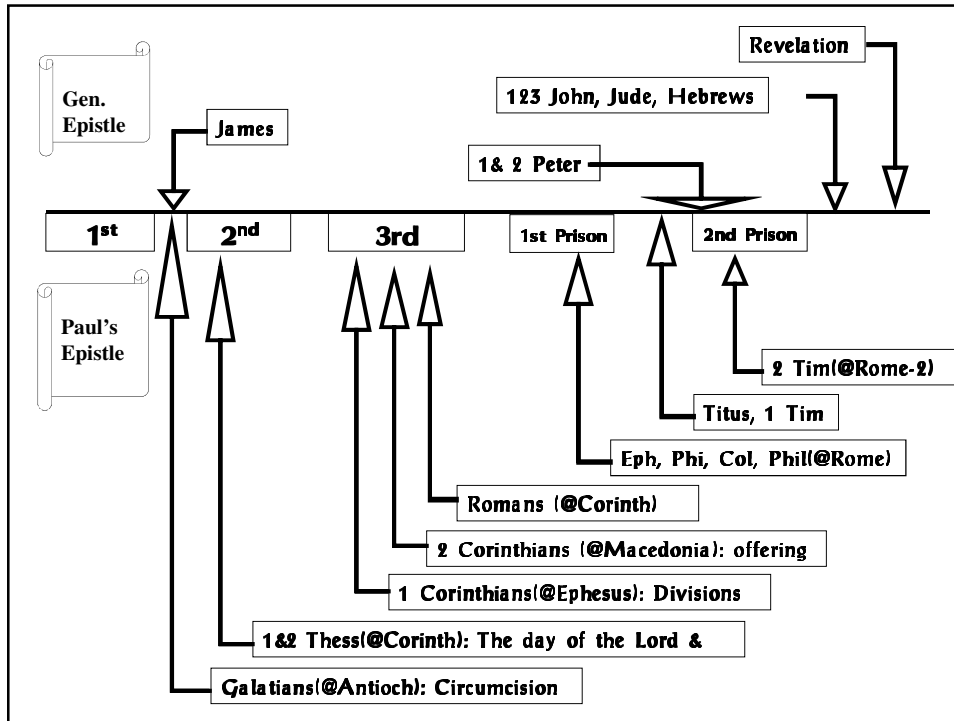

Macedonia

Ephesus

**1 Timothy**

Written {

- From: Macedonia
- When: b/w 2 imprisonments
- To: Timothy (Ephesus)

를

**Between the imprisonments**

1

## Ephesus

### 1 Tim 1:4

... et de ne pas s'attacher à des fables et à des généalogies sans fin..

1

## o Roman

o Troas

Ephesus

o Lystra

### 2 Timothy

Written { From: Mamertine(Roman Prison)  
When: 2<sup>nd</sup> imprisonment  
To: Timothy (Ephesus)

Mamertine Prison

1

# Lystra

## 2 Tim 4:1-4

2 prêche la parole, insiste en toute occasion, favorable ou non, reprends, censure, exhorte, avec toute douceur et en instruisant.

1

